

SPELEONICS 25

COMMUNICATIONS AND ELECTRONICS SECTION OF THE NATIONAL SPELEOLOGICAL SOCIETY

**Volume VII #1
June 2005**

Editor: Paul R. Jorgenson KE7HR
NSS 39382 FE ke7hr@cox.net

SPELEONICS is published irregularly by the Communications and Electronics Section (CES) of the National Speleological Society (NSS). Primary interests include cave radio, underground communication, cave lighting, and cave related applications of amateur radio. NSS membership is not required.

Contributions of articles for publication is **highly encouraged**.

Contents of *SPELEONICS* 25 - Volume VII #1

Page 1	Title, Information, Contents
Page 2 - 4	A Firefly for Digital Cameras John T.M. Lyles
Page 4 - 6	Minutes of the 2004 Annual Meeting
Page 7 - 14	Optimizing Circuits Using Computer Simulation Brian Pease
Page 15 - 19	Princeton Tec Yukon HL Hybrid + Headlamp John T. M. Lyles
Page 20 - 24	A Luxeon LED for the Petzl MY06 John T. M. Lyles
Page 25 - 26	80 Meter HF Radio Experiments Paul R. Jorgenson

All issues of *SPELEONICS* are available online:

<http://www.caves.org/section/commelect/spelonic.html>

**Send articles for publication to:
Paul R. Jorgenson KE7HR
ke7hr@cox.net**

Modifying A Firefly for Digital Cameras

© 2004 John T. M. Lyles

The Firefly2 slave is a commercial product based on Gibson's circuit [1]. It is especially useful for cave photography, being sensitive to the IR component emitted by xenon tube flashes. Off camera flash units can be triggered without a hotshoe connection, while the visible light of an on-board camera flash can be attenuated using a piece of film. This produces dynamic side-lighted photographs. The rising popularity of digital cameras has added a new tool for creative cave photographers. However, there are compatibility problems with many of the new cameras and single pulsed slave units such as the Firefly and Vivitar or Wein 'peanut' slaves. Likewise, conventional slave/strobe systems made by Wein and Morris don't work with these cameras. The reason is that many of the cameras emit a pre-flash at lower power, in order to gauge the exposure before the main flash pulse is fired. This feature may be compounded with a red-eye reduction flash, which also confuses single-pulse slaved strobes. Some cameras allow turning off the redeye preflash, while others even disable the exposure-adjusting preflash when set in manual exposure mode. Determining this from camera specifications, brochures, and internet discussion groups is often confusing and frustrating.

My first digicam was a Nikon Coolpix 800. A friend had a Coolpix 990. We both tried some in-cave photography using a Firefly2 and an external electronic strobe. His shots were well-lighted, while mine were dark! The controlled preflash was setting off my Firefly too early for the main shutter. His Coolpix 990 didn't use a preflash. Instead of replacing my camera or my slave, I designed a dual pulse Firefly modification. In 2002 David Gibson and I exchanged ideas, as he had independently developed a similar mod based on his RALF circuit, which used 74HC123 one-shot multivibrators [2][3]. There are also at least three commercial sources of slave/flash heads, which have switchable settings for 1 flash or multiple preflashes. These costly devices preempt using inexpensive "yard-sale" or pawn shop strobes, which cost about ten dollars and are worthwhile in a cave pack.

To start the project I needed to know what sort of preflash timing I was dealing with. Using a UDT PIN photodiode (model 10AP) and Tektronix analog storage scope, I was able to capture the sequence. The preflash was about 88 mS before the main flash for the Coolpix 800. A circuit was devised which would only trigger the Firefly output switch (an opto-triac) when a second light pulse was detected within a certain timing window. I used two non-retriggerable one-shot multivibrators since the pair could be obtained in low power CMOS to be compatible with the extremely low power consumption of the Firefly2 (~10 μ A drain except when triggering). The complete circuit is shown in Figure 1, along with associated waveforms.

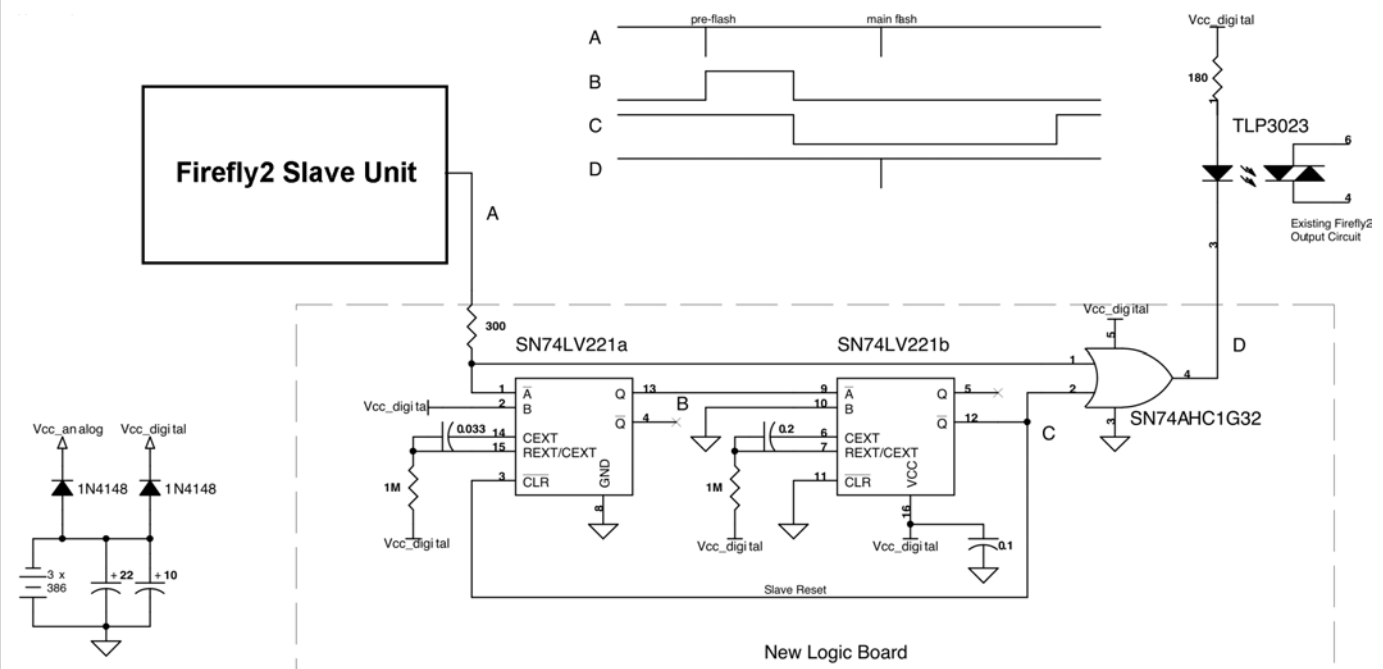

Figure 1

(Continued on page 3)

(Continued from page 2)

A dashed line separates the standard Firefly2 circuitry from the new logic addition. The two one-shots are in a dual package, as a 74LV221, especially designed for voltages from 2 to 5 volts. The single OR gate is a tiny logic part #74AHC1G32, which has Schmitt trigger action on the inputs. It is similarly specified for low voltage and power consumption.

Circuit Description



Figure 2

The first one-shot Q output (pin 13) goes high after the preflash is detected, as in waveform B. It changes state after 45 mS, triggering the second one-shot on its falling edge. The unit is then armed for the main flash. This second one-shot switches low at its Qbar output (pin 12) for about 0.2 S, as in waveform C. During this time the main flash fires on the camera. The main flash pulse and the Qbar output are OR'd to produce the final trigger to the opto-triac (TIL3023 in my Firefly2). Waveform D shows the delayed pulse for the opto-triac, which then switches the hot shoe in synchronism with the main flash impulse from the digicam. The advantage of using the '221 monostables is that they will complete their timing cycle before being able to be retriggered. This effectively de-bounces the Firefly2's op amp, which "chatters" when it transitions from a flash impulse. Feedback is applied from Qbar of the second one-shot, back to the clear input of first one-shot at pin 3. The modified Firefly2 slave ignores any single flash within a 0.25 second period, and also any multiple flashes less than 45 mS apart (as well as multiple impulses from the amplifier). It is armed by a single flash, but only switches its hotshoe output if another flash impulse arrives within the 0.2 second window of the second one-shot. After this times out, the entire circuit is reset and ready for another sequence. By resetting promptly, it is not susceptible to a second isolated flash event within a few seconds.

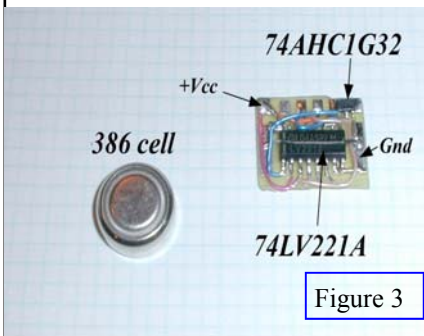

Figure 3

Construction

In order to fit this logic into the existing Firefly 2 housing, I initially used surface mount components and discrete wiring. After one failed attempt using dead bug construction, where I soldered tiny wires to the pins as the ICs were glued upside down to the Firefly PCB, I used a separate substrate for the logic modifications. A #9081 Surfboard (available from DigiKey) was modified by cutting away some of the extra pads to produce a small board that fit into one corner of the Firefly2 main PCB. Figure 2 shows the Surfboard before being cut and afterwards with the placement of the '221 IC. Figure 3 shows the complete logic board before being attached to the Firefly PCB. Figure 4

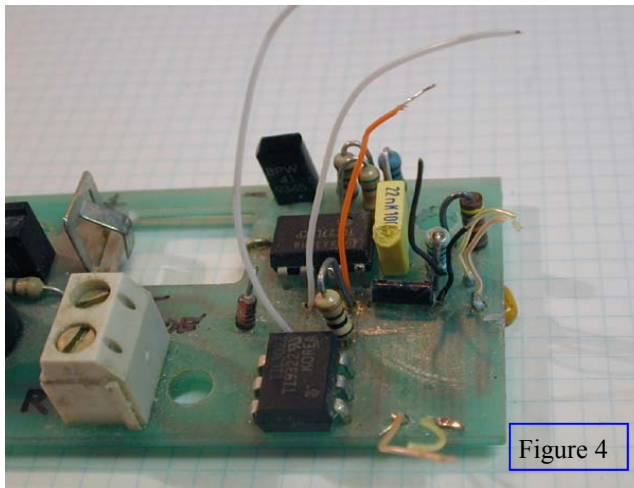

Figure 4

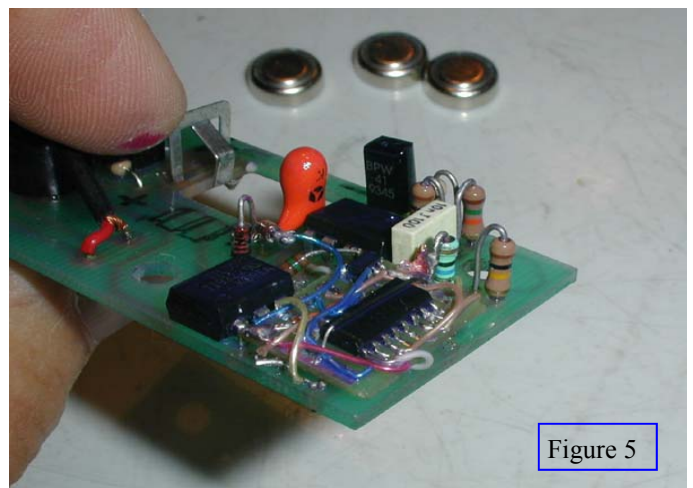

Figure 5

(Continued on page 4)

(Continued from page 3)

shows the Firefly2 PCB before adding the logic and fig. 5 shows the completely modified board. The timing components (two resistors and capacitors) are mounted on the back of the Firefly2 PCB where there is space, and connected with wires to the appropriate pins on the Surfboard.

Initially I designed for tighter timing tolerances, but later discovered that the '221 timing varies with battery voltage as well as with temperature; this caused my timing acceptance window to drift out of spec. This was compensated with the shorter first delay and extended second delay in the final version. It now works with a variety of digicams and for a range of battery voltages.

In August of 2004, I replaced my Coolpix 800 with a Canon Powershot S60. The main flash occurred 110 mS after preflash, within my 0.2 second window. As I began testing the prototype, it became evident that the Firefly2 would become unstable and continue to flash randomly. This was traced to the TLC27L2 op amp, which was unstable after the first impulse of a flash. Improved decoupling between the logic Vcc+ and the op amp Vcc+ was needed, as the current spikes of the logic transitions was causing the sensitive op amp to toggle repeatedly. The battery approach taken in the commercial Firefly2 (not in Gibson's circuit) uses three #386 silver oxide cells for 4.5 volts. Vcc is dropped to four volts through a series protection diode, provided for accidental cell reversal. With the transient current of the logic and opto-triac during a flash event, this diode drop was fluctuating and causing changes in Vcc for the op amp. Knowing how easy it is to install Firefly2 batteries backwards, I decided to add a separate series diode for the digital portion, adding ample capacitance on the battery side of the diodes and on both analog and digital supplies. This improvement stabilized the Firefly2, when combined with a minor change in the passive components that control the op amp response to fast impulses. Due to the high impedance circuitry involved in the Firefly2, I conformally coated the circuit boards for moisture protection.

David Gibson recently announced (July, 2004) a programmable add-on board to his slave circuit, which uses an 8 pin PIC microcontroller for the timing detection [4][5]. It fits into the housing that he recommends for his original slave unit, but not into a Firefly2 case. The tiny logic circuit described here easily fits into the housing, requires no jumpers, programming or switches, and overall current consumption is still measured at less than 10 μ A. Battery life should continue to be several years. I have successfully tested the modified Firefly2 with several recent digicams, two from Nikon, a Sony DSC-P100, and the Canon S60.

[1] Gibson, D., "A High-Performance Flashgun Slave Unit", CREG Journal of BCRA Cave Radio and Electronics Group, #45, Sept., 2001, pp. 3-8.

[2] Gibson, D., "A Slave for RALF", CREG Journal, #22, December, 1995, pp. 8-10, 21.

[3] Gibson, D., "Flashgun Slave Unit for Digital Cameras", CREG Journal, #48, June, 2002, pp. 24-25.

[4] Gibson, D., "Slave Unit for Digital Cameras", CREG Journal, #55, March, 2004, p. 24.

[5] Gibson, D., "Slave Unit for Digital Cameras, Version 2", CREG Journal, #57, September, 2004, pp. 16-17, 24.

**Minutes of the Annual Meeting of the
Communications & Electronics Section of the NSS
Brian Pease, Sec/Treasurer
7/12/04 1:00 PM**

Attendance:

37 people put their names on the sign-in list either at the luncheon/business meeting or at the program session. This compares with 33 last year and 37 the year before. We now have a total of 76 "official" members with 19 known hams and only 2 people who did not list an email address. The NSS requires us to maintain a list of members, so we simply defined our membership as consisting of all of the people who have signed in at the annual meeting sometime within the last 5 years. The only officers present were Bart Rowlett and Brian Pease.

Minutes from 2003:

Brian read the 2003 minutes, which were unanimously approved.

Treasurer's Report:

Brian Pease (Sec/Treasurer) reported that we have \$1512.28 as of 7/1/04 in the Section's money market account. Last year we had \$1525.07. The only expense was \$22 for our NSS web space.

Old Business:

(Continued on page 5)

(Continued from page 4)

Due to the difficulties involved in tracking down the people on the old membership list, which consisted of people who had paid in advance for paper issues of Speleonics, Brian has decided to deal with refunds on a case-by-case basis.

Henry Schneider scanned and converted issues 1 & 2 of Speleonics to PDF and cleaned them up to very high quality.

David Larson found a way to quickly convert the remaining back issues (3-21) to PDF with minimal cleanup. The quality is more than adequate.

Gary Bush, our Communications Chair, recently discovered that his free web space had been drastically increased to 100 MB. He has uploaded the back issues to his web space with links from our NSS Website <http://www.caves.org/section/commelect>. All Speleonics issues are now on the web, including an index to the (formally) paper issues.

Bart Rowlett, who operates the Speleonics email list, explained how to subscribe. Send an email to speleonics-request@altadena.net with "subscription" in the subject line and "subscribe your email address" on the first line of the body. An alternate way to subscribe or get info on the list is to visit <http://www.altadena.net/mailman/listinfo/speleonics>. He said that due to the current volume of spam, he may not catch legitimate messages that were automatically rejected for some reason such as not being sent from the subscriber's normal email address.

New Business:

Brian Pease brought up the fact that we were not having the in-cave workshop at this year's convention that we talked about last year. We decided to start planning for one in Alabama next year. Brian suggested that we have the workshop on Sunday when the only conflict would be the Hydrology Field Trip. I suggested taking some photos above and below ground. The results can be organized Sunday night and presented/discussed during the Session on Monday.

Doug Strait volunteered to find a place for the workshop next year. We need a cave close to the convention with adequate parking close to the entrance. It should have an easy entrance to a walking passage that goes under a rising hillside that will allow tests through 200 ft (and maybe 300 ft) of overburden. It should take only a short time (say 15 minutes) to walk from the test site in the cave to the point on the surface directly overhead.

Bill Franz said that he will coordinate with the Survey & Cartography Section.

On the surface, we would like to demonstrate the measurement of conductivity with a radiolocation set and also with a Wenner electrode array. We may demonstrate the simple measurement of earth current impedance. We will also use the radiolocation set to demonstrate tracking and to locate points on the surface directly over the underground location(s) and estimate the depth(s). We will attempt two-way communication between cave and surface by several methods at one or two depths:

- 1) Brian's 185 KHz transverters with 1 m² loop antennas at the deepest depth.
- 2) Possibly test the transverters with earth-current dipoles.
- 3) 2-way digital text comms using Ray Cole's PSK-31 radios.
- 4) Brian's 27 MHz CB handhelds (at a shallower depth).
- 5) HF radio at one or two frequencies (voice and/or CW) with fixed antennas (at the deepest depth) or mobile antennas shallower.
- 6) We will measure in-cave comms range in curving passages using the HF radios; the CB radios; 2-meter handhelds; FRS radios.
- 7) Demonstrate Ted Lapin's light-sensitive caver counter.
- 8) Measurement of water conductivity with pocket meter.
- 9) Possible coordination with the Survey & Cartography Section showing use of radiolocation to check cave map accuracy and align remote parts of cave on the topo map using radio/GPS. Radiolocation accuracy could be checked by surveying between two radiolocated points both on the surface and underground.

Presentation:

Brian Pease gave a presentation on his new Hi-Power 3496 Hz Radiolocation Beacon.

Abstract

An improved high power 3496 Hz beacon transmitter has been designed, built, and tested in the field. It uses the well-known shunt-capacitor series tuned class-E power amplifier circuit with two inductors and two capacitors. This new beacon has several advantages over the classic design that has been used for many years, which is properly called a class-E tuned power amplifier with one inductor and one capacitor. The old design used narrow pulses to drive the loop, which induce large voltage transients on the power MOSFET and large current tran-

(Continued on page 6)

(Continued from page 5)

sients in the DC supply. The maximum output (Magnetic Moment) was about 50 Amp-turns-m² for 5 Watts input. Any attempt to increase the output resulted in larger transients, reduced efficiency, and DC supply problems. The new circuit can be easily be trimmed for high or low power with various DC supply voltages. It was easy to trim the new circuit for 21 Watts output and 106 Amp-turns-m² with a 15 V supply. The new beacon was field tested at ~600 ft (180m) depth in Belize. It worked reliably and the signal on the surface was more than adequate.

Show and Tell:

- 1) Brian Pease showed his version of Ian Drummond's CB/185 KHz transverter. The block diagram and schematic are at <http://Radiolocation.tripod.com>. I altered the circuit to improve receiver sensitivity and dynamic range. He mentioned two other voice radios: the British Heyphone (<http://www.heyphone.org>) and the French Nicola II (http://perso.wanadoo.fr/graham.naylor/cave_radio).
- 2) Brian Pease mentioned that he still has a few circuit boards for his Radiolocation receiver and beacon. He sold 3 boards and has 3 left.
- 3) Brian Pease explained how large flat plate electrodes can be used with "earth-current" dipoles in place of the ground stakes. He showed a foil-backed building insulation that will make a rugged light-weight electrode. The material, called Reflectix, is basically bubble wrap with aluminum foil bonded on both sides. It can double as a camp mat and equipment padding. Home Depot has it, at least in the NE.
- 4) Brian Pease showed a 2 Watt 27 MHz CB AM handheld radio with a 4 ft center-loaded whip that he has used for thru-the-earth voice comms. It will easily penetrate 60 ft of ordinary limestone, and 200-300 ft of low conductivity metamorphic rock (marble, dolomite). These radios cost him less than \$5.00 each at a radio auction.
- 5) Ray Cole showed his 24 LED headlamp with switching current regulator and variable brightness. It will work on 3-6 volts, which lets it work on 2,3, or 4 AA alkalines, 3 or 4 NiCad or NiMH cells, or a single 3V lithium. He explained that many lamps have been built and that he has circuit boards for the surface-mount circuit. See <http://members.cox.net/k4gaa/caving.htm>
- 6) Ray mentioned that he is making progress on 2-way text comms using PSK-31. He persuaded Peter Martinez, who originated the software, to removing the "windowing" that limits the bandwidth to 31 Hz. Without the windowing, the transmitter can operate in a simple and efficient saturated mode. He gave a demo of the transmitted sound at 3496Hz. He expects to be able to demo it next year.
- 7) Doug Strait built a very compact 874 Hz pulsed beacon to help locate a new entrance to a 400 ft deep cave with 7 drops near the Suwanee, TN NSS Convention site called Suwanee Plunge. A tight 1500-3000 ft crawl between 2 of the drops seemed to be near the surface at the far end. He built the entire beacon, including loop antenna and battery into a flat Otter box. He said battery drain was 4 Watts with a Magnetic Moment of 2 A-T-m². With his receiver, the limit of detection was about 300 ft. Explorers set up the beacon on their way in, and he had located it and had dug the entrance open enough to talk to them when they retrieved the beacon on their way out.
- 8) Doug talked about the Candlepower Forum website. He got involved in a project to build a 1 cubic inch flashlight using a 3 Watt Luxeon white LED chip. He used a Texas Instruments low dropout linear regulator operating in its current-limiting mode as a 1-component current regulator for the high-power mode. The TPS-73101 limits at ~250 mA, the TPS-73201 at ~425 mA, and the TPS-73601 at ~650 mA. He used a "digital transistor", a PNP device with built-in base series resistor, as a current limiter for the low-power mode. The emitter connected to B+, the base to Negative, and the LED to the collector.

Elections:

Joe Hruska ran the elections.

The Existing officers were reelected by acclimation:

Bart Rowlett as Executive Chair,
Brian Pease as Secretary-Treasurer,
Gary Bush as Communications Chair (Website),
and Paul Jorgenson as Publications Chair.

Optimizing Circuits Using Computer Simulation

The Quest for the Ultimate Class-E Transmitter

Brian Pease

1/26/05

Introduction

The primary purpose of this paper is to convince more experimenters to try computer simulation of their circuits by providing a step by step tutorial using actual cave-radio designs. A powerful version of the Spice III circuit simulation program is available as a free download on the internet (**ref 1**). LT-Spice (also known as SwitcherCAD III) is available from Linear Technology as a development tool for their switch-mode power supply ICs. It has been optimized for switching design (which is what Class-E is!) but has analog capability as well for op-amp circuits, linear amplifiers, etc. This is a powerful, fast, professional program, not crippled in any way, other than that most of the IC models included are Linear Technology products. Using the included component models, one can rapidly create a schematic, including losses for imperfect parts, run a simulation, then probe any node to see voltage and current waveforms. RMS & Average values, and frequency spectra, can be computed instantly for any waveform.

LT-Spice has been used to successfully simulate three 3496 Hz Class-E radiolocation beacon transmitter circuits. The traditional beacon design (**ref 2**) using one transistor, one capacitor, and a tapped loop was found to be a relatively poor and inefficient design, which can be improved in two ways that are explored in this paper. The tutorial will lead you step by step from schematic creation through actual simulation of this circuit, using free software on your own computer.

The Class-E circuit with an RF choke, shunt capacitor, and series-tuned loop (**ref 3**) is flexible, powerful, and very efficient, but must be tuned with an oscilloscope by observing waveforms, because there is no distinct peak or null in either loop or battery current. The currents rise (or fall) smoothly while the loop is tuned through resonance.

A variation of this second circuit (**ref 4**), first analyzed by Mark Mallory, WB7CAK, in 1988 (OUCH! how did I ever miss this?), is much better behaved, with peak loop current occurring exactly at peak DC supply current. This design replaces the RF choke with a specific value of inductance, which resonates with the shunt capacitor to form a broad tank circuit. Mark derived equations to precisely calculate inductor and shunt capacitor values for a desired frequency, supply voltage, and power level. A second winding on the inductor acts as a transformer to match the calculated output impedance of the circuit to the low resistance of the series-tuned loop. This third Class-E circuit might also be used as a very simple high-efficiency amplifier for LF earth current digital communications using a one-tone-at-a-time mode such as MFSK-16.

The Simulation Program

The Spice simulation program, originally *Berkeley Spice*, has been around for many years. I downloaded a very powerful free version of Spice III from the Linear Technology website, <http://www.linear.com/software>, and strongly recommend that you do the same. The program is officially known as *SwitcherCad III* but commonly as *LT-Spice*, and is used by some professionals in place of expensive professional software. It will run on Windows or Linux. It can do DC, transient, small signal AC, and noise analysis. The Help files are really useful and the basic features are very easy to learn. It only takes a few minutes

to create and simulate a simple circuit such as the traditional beacon circuit shown in **Figure 1**. Click Edit\Component to select passive and active parts, voltage sources, and drive signals, then place them on the schematic. In the Help files, see FAQs and LT-Spice\Circuit Elements for details. Custom parts can be created, and IC models can be added. Values can be entered in whatever form is preferred. A 1 microfarad capacitor can be entered as .000001; .000001F, 1uF, 1u, 1000000pF, 1E-6, 1e-6. The same applies to voltage, current, time, frequency, etc. The only rule is that spaces are not permitted, i.e. 1.0uF works but 1.0 uF doesn't. In general, the program assigns reasonable values to anything that you don't specify. For exam-

(Continued on page 8)

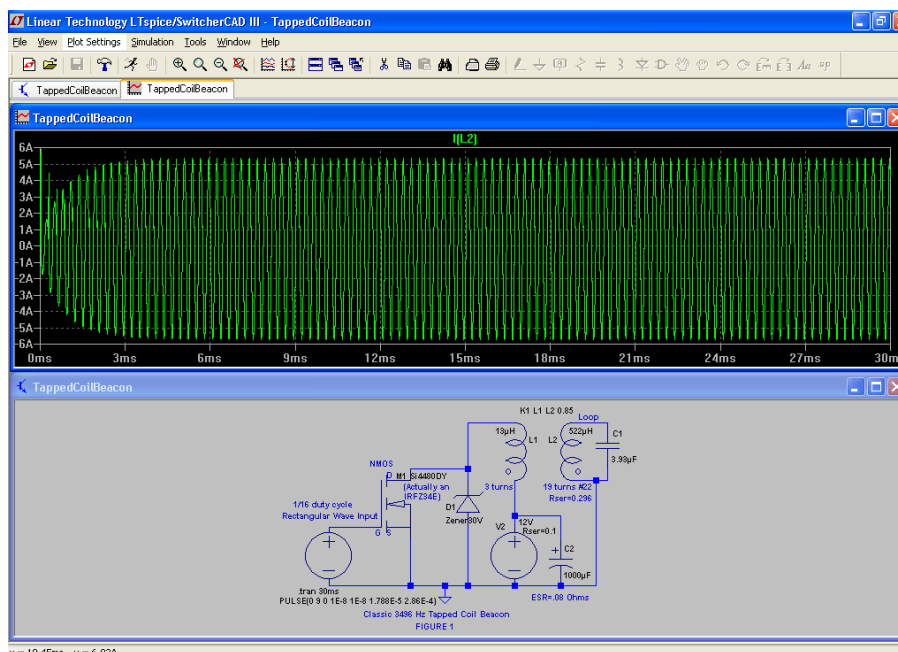

(Continued from page 7)

ple, a capacitor is assumed to have no loss and infinite voltage rating. Inductors have (nearly) infinite Q. A resistor can handle any power level. A diode or MOSFET will not break down if its voltage rating is exceeded. A transformer is assumed to have perfect coupling between windings.

TUTORIAL EXAMPLE 1 Creating a 3496 Hz Tapped-Coil Beacon Schematic in LT-Spice

Once a schematic is created, a simulation can be run on it and “what-if” games played. The finished schematic is a tiny text file that can be emailed to another nerd who can then run the simulation on his own copy of LT-Spice. The only caveat is that you must alert your friend of any special components you used that you added to the library, such as the zener diode below. Forget video games! Simulations are fun!

For this example, select File\New Schematic, then select File\Save As and name the file TappedCoilBeacon or some such.

For the 3496 Hz tapped-coil beacon of **Figure 1** (the driver circuit is not shown), which uses a 22 inch diameter loop, the first step is to create a 30 Volt zener diode, which is not included in the LT-Spice component library. See Help\FAQS\3rd party models. The diode library file is a simple ASCII text file which can be edited either in LT-Spice with File\open, or with any text editor, such as WordPad. On my computer, the file is located at C:\Program Files\LTC\SwCADIII\lib\CMP\standard.diode. Add the following line, exactly as shown, to the top of the diode list, then select File\Save:

```
.model Zener30V D(Ron=.1 Roff=1Meg Vfwd=.4 Vrev=30 type=zener)
```

To model the 22 inch diameter loop antenna, which consists of 19 turns of #12 solid wire tapped at 3 turns from the B+ end, I first measured the inductance of the complete winding ($L_2=522 \mu\text{H}$). See **Appendix A** for simple methods of measuring inductance and Q. I then resonated the loop with low loss polyprop capacitors and carefully measured the Q (37.8). I could then include all of the loss as loop series resistance (0.296 Ohms). I found it easier (and more flexible) to model the 3-turn tap as a separate lossless winding, L_2 . See **Appendix C** for methods of including tapped-coils in LT-Spice. LT-Spice requires entering the winding inductances, then internally calculates the turns ratio of a perfectly coupled coil as the square root of the inductance ratio. $L_1=13 \mu\text{H}$. The remaining parts will be described as the schematic is being created.

Start creating the schematic with the MOSFET. Select Edit\Component\mos and press [OK]. Now position the component, then left-click to place it. Right-click to return to normal editing. Right-click the MOSFET symbol to see its properties, then press [Pick a New MOSFET]. Highlight the Si4480DY, about halfway down the list, then press [OK]. This MOSFET has $R_{on}=0.04$ Ohms, similar to the actual transistor. These are special simplified models that run very fast, not slow sub-circuits.

To move a component after placing it, left-click the Move “hand” icon; left-click the hand over the component; move it as desired, then left-click once more to fix it in position. You can also move text. When you move an existing component, you can rotate or mirror it at the same time with the menu icons. Right-click to remove the hand. Keeping parts close together will improve legibility when the schematic is reduced to half-screen.

To add wires, left-click the wire icon (pencil), move the crosshairs to a lead, then left-click to attach a wire or make a bend. Wires can be drawn right through components.

NOTE: The Edit\Component\Misc library contains many interesting parts including some European symbols.

To remove a component, wire, or comment, left-click the “scissors” icon, then left-click over the unwanted item. Right-click to remove the scissors.

To add the zener diode, select Edit\Component\zener and press [OK]. After placing the diode, Right-click to see its properties, then select [Pick a New Diode]. Highlight the 30-Volt zener that you created earlier, then press [OK].

Capacitors and resistors are easy. Select Edit\Capacitor (or Resistor) and place as before, then right-click and enter your value, such as “3.92uF” for C1, or “1k” for a resistor. You can also select a specific capacitor from the database. For electrolytic capacitors such as C2 (1000uF), select Edit\Component\polcap. For C2, include Equivalent Series Resistance (ESR) of .08 Ohms. Note that there are sufficient parasitic elements included in the capacitor model to simulate a quartz crystal!

For the loop, first select Edit\Inductor, and place L1. Right-click and enter inductance of 13uH. Also check mark “Show Phase Dot”. Next, select Edit\Inductor again, then left-click the *Mirror* icon and place L2. Enter inductance of 522uH, series resistance of 0.296 and again check-mark “Show Phase Dot”. The phase is not important here, but I want to show how to do it. The dot can be moved to the top of an inductor by rotating and mirroring.

LT-Spice must be told that L1 and L2 are coupled together. They are not perfectly coupled. I discovered this when I first simulated the circuit using a coupling coefficient of 1.0. The large positive voltage transient that is present in the actual circuit, and is snubbed by the zener diode, was not present in the simulation. Using a technique from a college text, described in **Appendix B**, I measured a coupling coefficient $k=0.85$ between L1 and L2. I cut the loop at the 3-turn tap to do this. I could (and should) have added a temporary 3-turn winding for a more accurate result. To couple the inductors, select Edit\SPICE Directive then type: K1 L1 L2 0.85 with spaces between the 4 entries, then press [Enter]. Position this text over the inductors and left-click to place it.

For the 12 Volt DC source select Edit\Component\voltage, place it, then right-click it to display Properties. Enter 12V

(Continued on page 9)

(Continued from page 8)

for “DC Value” and 0.1 for Series Resistance, then press [OK]. Without some resistance here, C2 would be shorted out, which would make the simulation quite different. The strong current pulses here are one of the problems of this circuit.

For the 1/16 duty cycle drive select Edit\Component\voltage, place it, right-click to display properties, then press [Advanced]. Because this will be a transient simulation, select PULSE. Enter the following values to generate a continuous pulse train at 3496 Hz with 9 Volt positive pulses of 1/16 duty cycle with fast rise and fall times: Vinitial=0, Von=9, Vdelay=0, Trise=1E-8, Tfall=1E-8, Ton=1.788E-5, Tperiod=2.86E-4, Ncycles-leave blank. Note that entering 0 into Trise and Tfall, or leaving them blank, will not give infinitely fast rise and fall times. Spice defaults to times so slow that the duty cycle is not 50%! Enter fast times. Press [OK].

Each circuit must have a ground. Select Edit\Component\Place GND, place it, and connect it to the circuit. Include any other wires needed to complete the circuit. Use the text icon to add comments. Now save it!

Running the Tapped-Coil Beacon Simulation

Now for the fun part! Select Edit\SPICE Analysis, then click the Transient Tab. Enter Stop Time=.03 to run the simulation for 30 ms, or about 100 cycles. If the simulation runs too slowly on your computer, even 10 ms will work fine. You can magnify the waveforms later to see details. Enter “0” for Time To Start Saving Data to display every cycle from the very first. This will be changed later. Press [OK]. Now just click the *Run* icon (running person). When the “Select the Waveforms to Display” window appears, either select one or more waveforms, or simply press [OK]. The screen will now split with waveform(s) appearing in the upper half. When the simulation is complete, current and voltage waveforms have been computed for every node.

Left-click anywhere in the schematic window to activate it, then move the cursor slowly over the schematic. At each node, the cursor will change to a red voltage test probe, and to a black current-clamp on each component lead. The name of each probe point (and of the resulting waveform) appears in the lower left corner of the schematic window. If the schematic is too small to read, either drag the bottom of the window to enlarge it, or press [Maximize] to enlarge it to full screen, press the same button to shrink it again.

Note that it is possible to have two circuits on-screen simultaneously, which allows side-by-side comparison of waveforms.

Move the cursor to select the current probe at the top of L2, then left-click it to display the waveform. See **Figure 1**. Double-clicking will delete all other waveforms and display just the loop current. You can display as many waveforms simultaneously as desired. Move the cursor to the waveform display and left-click. This changes the selections at the top of the screen to waveform related items. Note that the cursor is calibrated in both current and time. See that it takes perhaps 5 ms for the loop current to reach its final value. Left-click back in the schematic window then select Edit\Spice Analysis and change *Time to Start Saving Data* to .005 to start the waveform display after 5 ms. Re-run the simulation, which may run faster this time. The entire loop current waveform will now be the steady state value. Note that the time scale still starts at “0”, which is now really t+5 ms. Now add MOSFET drain current and the 12VDC source current waveforms to the display.

To View the waveforms in detail, put the cursor at the top of the waveform, left-click and hold while moving the cursor down and to the right to enclose the desired number of cycles in a box. It works like a crop tool for pictures. When you release the mouse button, the enclosed waveform expands to fill the window. Now you can add the waveforms for drive voltage, MOSFET voltage and current to see exactly how the beacon works. Do not use these magnified waveforms to compute RMS or Average values, as described next, unless you have an exact integer number of cycles. Note that when you re-run the simulation, the display reverts to the original number of cycles. The *Zoom Full Extents* icon will also do this. Do one or the other now.

Now for a little magic! Select Edit\FFT to bring up the Fast Fourier Transform window. Press [OK] to bring up a window where you can select one or more of the visible waveforms to display. Press [OK] to display amplitude vs. frequency. This Spectrum Analyzer display is calibrated in dB relative to the RMS value of the waveform, with the cursor readout calibrated in both amplitude and frequency.

Now get rid of the FFT window and move the cursor over a waveform’s text label near the top of the screen. A little hand will appear over the label. Press and hold the [Control] key, then left click on the waveform label. The little window that appears will display both the RMS and Average values of the **visible displayed waveform**. Click a second time if it doesn’t show. This works for any waveform shape no matter how complex. This function is the reason for wanting many cycles in the display, and for displaying only the steady state waveform. Of course, with care, these values can be obtained from a precise single cycle (360 degrees) of a waveform. One must be careful when using the RMS and Average values, especially when trying to calculate power and efficiency. It is important to note that the computed RMS value includes both the AC and DC components. In general, use RMS values for power loss in resistance and Average values for power into or out of fixed voltage devices such as batteries and zener diodes. For DC power input, use the Average 12 V source current (528 mA) to obtain 6.34 Watts input. The 0.1 Ohm source resistance is just another loss $(1.1314A\text{ RMS})^2 (0.1\text{ Ohm})=0.128\text{ Watts}$.

Next find the RMS loop current (3.8945 Amps). The very small Average value shows that you do not have an exact integer number of cycles displayed. Output power (loop dissipation) is $I^2R=4.49\text{ Watts}$. Defined in this manner, efficiency is

(Continued on page 10)

(Continued from page 9)

only 70.8%. The simulation has been tuned for minimum DC current, the same as my actual beacons. This is another drawback to the design, because a change in loop inductance, which can easily happen with a folding loop, causes an increase in circuit currents that can, and has, destroyed MOSFETS. If the value of C1 is gradually increased in .01 uF increments, loop current will also increase, but beyond a certain point efficiency will start to drop. Try changing C1 slightly either side of 3.92 uF to see that the circuit really is at minimum DC current. To change C1, right-click the current value of C1 on the schematic, to bring up a window where you can change it. Now run the simulation again, record the DC current, then repeat.

Where is the wasted 1.85 Watts of power going? As mentioned earlier, there is only 0.128 Watts lost in the 12 Volt source resistance. Using C1=3.93 uF, run the simulation then display zener diode current. Find the Average diode current (44.72 mA), then calculate the power loss ($30 \times .04472 = 1.34$ Watts). Obviously, most of the loss is due to the large positive transient that is snubbed by this zener each time the MOSFET switches OFF, right at the peak drain current. To appreciate the real size of this transient, delete the zener temporarily, run the simulation, then display MOSFET drain voltage to see the ~+800V pulse. Re-install the zener.

Display the waveform of C2 current and compute RMS current (1.211 A). The ESR loss is $(1.211 \text{ A RMS})^2 \cdot (.08 \text{ Ohms}) = 0.117$ Watts

The only remaining loss is Ron of the MOSFET. Display MOSFET current and compute the RMS value (2.1634 Amps). MOSFET dissipation due to Ron is $(2.1634 \text{ A RMS})^2 \cdot (.04) = .187$ Watts. Adding the 4 losses together gives 1.70 Watts, accounting for most of the 1.85 Watts of lost power.

Improvements to the Tapped-Coil Beacon

One way to improve efficiency is to reduce loss in the zener diode. See **Figure 2** Lift the bottom of the zener from ground, then connect the anode of a generic diode to the bottom of the zener and the cathode to the 12 V source. This re-directs some of the pulse energy back into the DC source. Right-click the generic diode and change it to a MURS320 3 Amp unit. Change the zener to a BZX84C12L 12 Volt unit. Run the simulation, compute average 12 V source current (486 mA) and loop current (3.889 A), then calculate efficiency, which should now be 76.8% instead of 70.9% for the original circuit.

A second improvement is to change the drive signal from 1/16 to 1/8 duty cycle. Theory says ~1/16 is best, but the

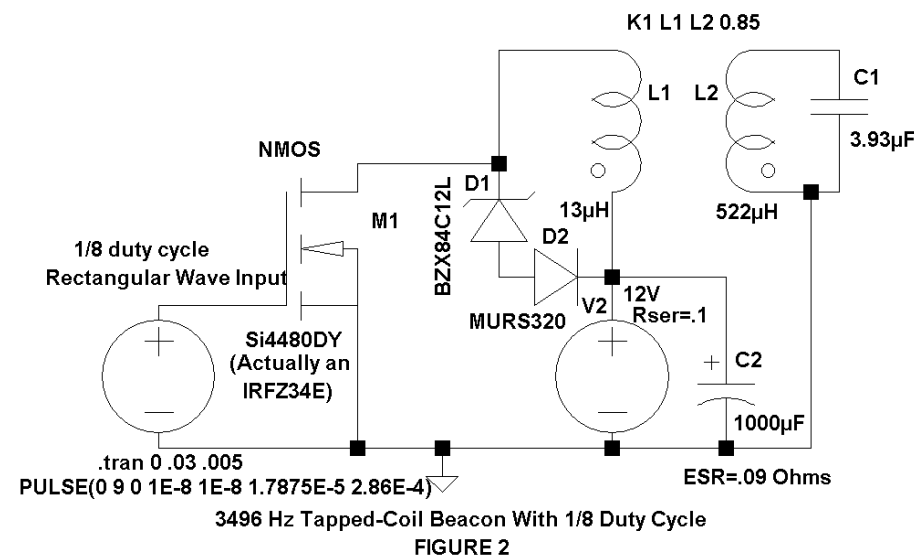

large transients cause losses. In an actual beacon, this could be easily accomplished by bending pin 7 of the 4060 osc/divider out at a right angle to the socket, then soldering a wire from the socket pin, under the board (NOT from the bent IC pin!) to the +9 volt bus. In LT-Spice, leaving the improved diode circuit in place, right-click on the drive source and change Ton from 1.788E-5 seconds to 3.576E-8, then run the simulation. The average 12 V source current is now 674 mA and loop current is 4.946 A RMS. Note that this duty cycle change does not de-tune the circuit, which remains in the DC current null. Calculating efficiency as before yields 89.6% for the two improvements combined; a worthwhile gain!

TUTORIAL EXAMPLE 2

3496 Hz Class-E Beacon With RF Choke, Shunt Capacitor, and Series Resonant Loop

This design has been described in Speleonics (ref 5) and in the CREG Journal (ref 6). The circuit, shown in **Figure 3**, can be entered just like Example 1 as a new file in LT-Spice called ClassE_Beacon. The input circuit (C1, D1, and R1) protects the MOSFET and batteries in case the driver stops oscillating with its output locked at +12 VDC. For safety, this circuit must be included in any of the beacon designs. The PULSE Directive on the schematic gives all of the values, in order, for the square wave source V2, except for Ncycles which is left blank. Just right-click V2. For Spice Analysis, the .tran Directive gives Stop Time=50 ms and Time to Start Saving Data=15 ms. Run the simulation, which is very fast, then calculate efficiency, which should be 92.5%. **Figure 3** shows the MOSFET drain voltage waveform, which is nearly perfect. See **Figure 4** for a perfect waveform.

The big advantage of this circuit is its ability to match different loops with your choice of supply voltage and loop cur-

(Continued on page 11)

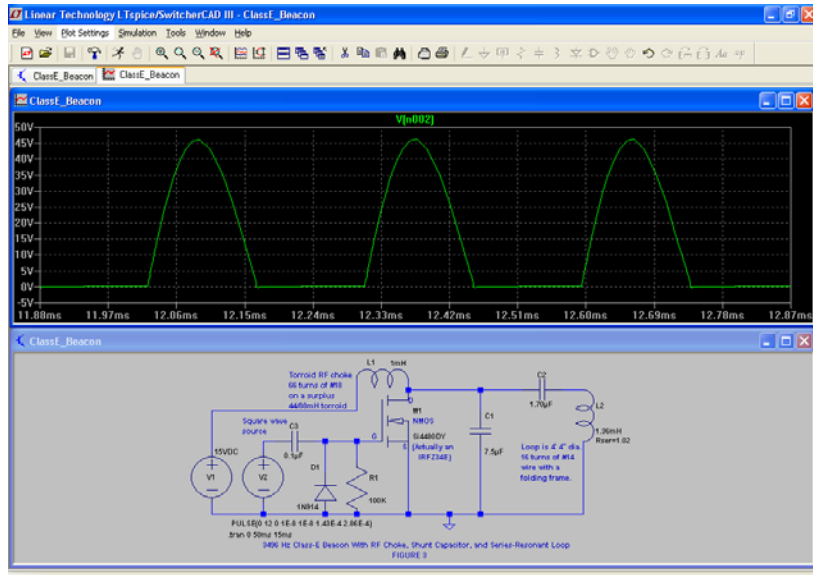

(Continued from page 10)

rent, all without using a matching transformer. The big disadvantage is the need to watch the drain waveform with an oscilloscope to tune it up. The DC source and loop currents vary smoothly when C2 is adjusted, with no resonant peak or null. C1 is not critical and can be varied in large jumps of 0.5 or 1uF.

Try a different DC source such as 12 volts, the select a DC current goal such as 0.5 Amps. T

Alternately tune with C2, watching the drain voltage waveform, which should first rise, then smoothly drop just to zero but no lower, then increment C1(hint: try smaller values). Compute efficiency once the goal is reached. I got 92.7%.

TUTORIAL EXAMPLE 3

Optimized 3496 Hz Class-E Beacon With Inductor/Transformer, Shunt Capacitor, and Series-Res. Loop.

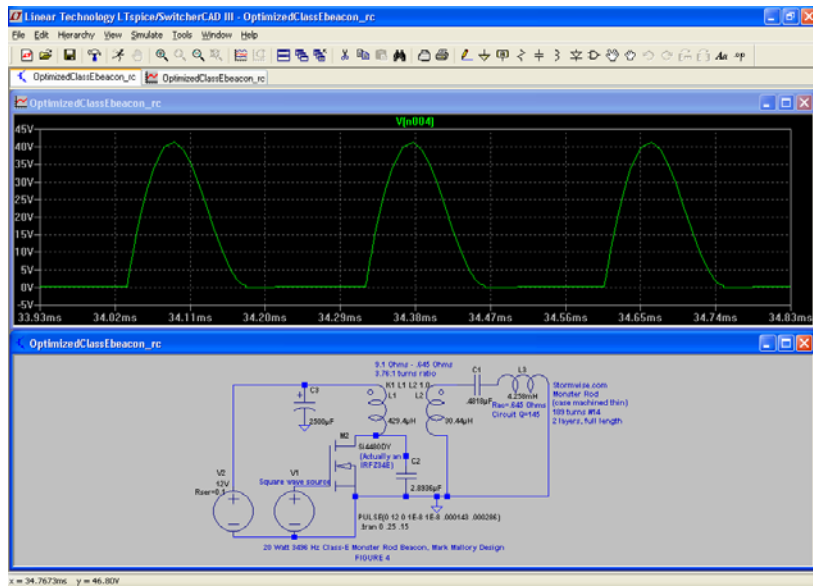

This remarkable circuit was created by Mark Mallory, WB7CAK, based on earlier work by others, and first documented in 1988 for use as a 179 kHz LowFER beacon (ref 4). Figure 4 shows the circuit, without the necessary drive protection that is described in Example 2. This circuit is a modification of Example 2, with the RF Choke L1 replaced by a specific value of inductance to form a broadly tuned tank circuit with the shunt capacitor C2. In this circuit, L1 must be a moderately stable high-Q inductor, as it is no longer just an RF choke. This tank circuit has a specific output impedance which can be matched to the series resonant loop with a secondary winding (or a tap) on the inductor. The circuit behaves perfectly, with maximum loop current coinciding exactly with maximum DC source current. When the loop is disconnected, DC current falls nearly to zero.

This circuit could be used with earth-current an-

tennas (with a suitable series-tuned output filter) by putting multiple taps on the secondary winding.

Another great advantage is that Mark worked out equations to calculate the component values for a given DC supply voltage, frequency, and output power. They are:

$$L1 = \frac{0.2085 V^2}{PF}$$

$$C2 = \frac{1}{[2(\pi)1.2915 F]^2(L1)}$$

$$Z = \frac{1.2638 V^2}{P}$$

L1=tank inductance, Henries

C2=shunt capacitance, Farads

V=DC supply voltage

Z=load resistance, Ohms

(Continued on page 12)

(Continued from page 11)

P=power input, Watts

F=operating frequency, Hz

Also:

V_{max}=peak MOSFET drain voltage=3.6311(V)

I_{rms}=RMS MOSFET current=1.1638(P/V)

Using 12 VDC, 3496 Hz, and 20 Watts input, the calculated values are:

L1=429.4uH

C2=2.8936uF

Z=9.1 Ohms

His recommended tune up procedure is to first tune the L1/C2 tank circuit for minimum DC current with the antenna disconnected. The L1/C2 tuning is very broad. The series-tuned loop is then connected and tuned for maximum DC current (and loop current). Usually, the series-tuned loop impedance will be less than the transmitter output impedance, so L2 can have matching taps (in place of the secondary winding) to adjust the power level to the design value.

The ferrite rod antenna has L=4.258mH, R_{ac}=.645 Ohms at 3496Hz when resonated with cap decade box. Calculated C_{res}=.4867uF (ignoring self-capacitance). See **Appendix A**

As a veteran circuit simulator, enter the circuit of **Figure 4** in LT-Spice as the new file Optimized_ClassE_Beacon. Display the MOSFET drain current waveform as in **Figure 4** to see its perfect shape. Note that the slope of the trailing edge of each cycle becomes horizontal as the voltage approaches zero. This reduces the switch-on loss of the MOSFET. The Loop is Hi-Q, which makes the value of C1 quite critical. Note how the DC source and RMS loop currents peak at the same value of C1.

Try disconnecting the loop to see what happens to the DC current. The easiest way to do this is to set the L1/L2 coupling coefficient k temporarily to zero. Now try a short circuit. With k=1, wire an 0.1 Ohm resistor across L2. There must be some resistance in each loop for the simulation to run. Measure the MOSFET RMS drain current and the current in R1. I calculated the MOSFET dissipation to be 3 Watts, with 29 Amps through R1!

C2 and the series resistance of V2 add realism to the DC source. As shown, the DC input power is 19.56 Watts, loop current is 5.3507 Amps, P_{out}=18.47 Watts. Efficiency is 94.4%, or 95.7% if the 0.1 Ohms in the DC source is ignored. Watch the power level drop when you change the mutual coupling of L1/L2 from 1.0 to a more realistic 0.9. This is not a big deal, just a warning that L2 will need more turns than theory suggests. Once an actual inductor L1/L2 has been wound, the coupling coefficient can be measured, then entered into the simulation to determine how many more turns will be needed on L2 to maintain the design power level. When constructing an actual beacon, it may be easier to delete L2 and put a series of taps on L1 (counting from the DC source end). This will not increase the coupling, but will make it easy to adjust the power level.

CONCLUSIONS

Computer circuit simulation is a circuit design powerful tool that can both save time and money. LT-Spice is a powerful, complete, easy to use circuit simulation program that is available at no cost. A proposed linear or non-linear design can be entered as a schematic in a few minutes, then run on the computer and probed for voltages, currents, efficiency, spectra, and more. Start-up times, spikes and transients can be investigated. Component values can be tweaked to tune resonant circuits or improve filter responses, etc. Drive levels can be changed to determine dynamic range. The list is endless!

LT-Spice is improving my beacon designs. The efficiency improvements to the classic tapped-coil beacon circuit (Example 1) suggested by simulation make it a much better design, although inferior to the true Class-E designs.

Tweaking the simulation of the Class-E beacon with RF Choke (Example 2) allows one to adjust the design for different loop antennas, supply voltages, and power levels, in the absence of accurate design equations. No transformer is needed.

The optimized Class-E circuit of Example 3 can be easily designed from equations, then simulated to check accuracy and adjust the turns ratio for less than perfect coupling. This simple circuit has high efficiency, is easy to tune, capable of high power, and can safely drive different loads including both open and short circuits without damage.

APPENDIX A Measuring Inductance and Q

Inductance can be directly measured with a digital LCR meter, but in general the Q cannot. The following equipment (or similar) is required to indirectly measure inductance and Q at the operating frequency, from which R

- 1) Sine wave signal source at the operating frequency.
- 2) AC voltmeter (or oscilloscope with accurate readout) with input impedance much greater than the resistor used in the test circuit, that will function at the operating frequency.
- 3) Low-loss Capacitor decade box.

(Continued on page 13)

(Continued from page 12)

Connect the equipment to the inductor L under test as shown in **Figure 5**. The value of resistor R should be at least within one decade of the expected impedance of the parallel-resonant circuit formed by L and C. Start with R=1k or 10k, and change R later.

- 1) Set the signal generator to the operating frequency, using a frequency counter if at all possible.
- 2) Set the signal to a level convenient for the ACVM.
- 3) Adjust C to the exact peak value of V2.
- 4) Record the values of C, V2, and V1

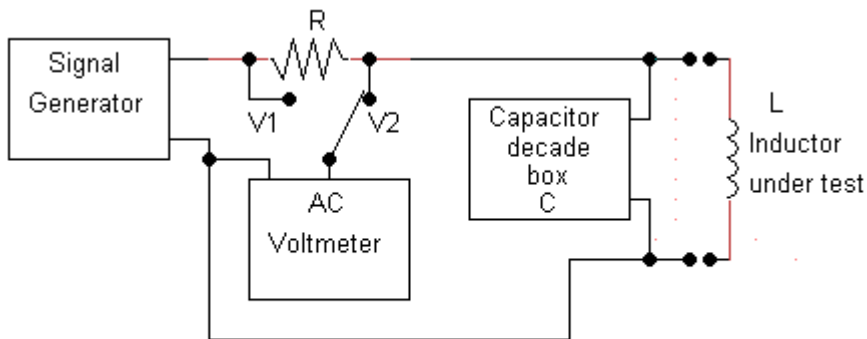

Inductance and Q Tester
FIGURE 5

The inductance:

$$L = 1 / [2(\pi)(\text{freq Hz})]^2 [C] \text{ Henrys}$$

$$\pi = 3.1416$$

The reactance of L:

$$X_L = 2(\pi)(\text{freq Hz})(L) \text{ Ohms}$$

Now, the parallel resonant impedance (resistance) of L & C:

$$Z_{\text{res}} = V_2(R) / (V_1 - V_2) \text{ Ohms}$$

And the Q of inductor L:

$$Q = Z_{\text{res}} / X_L$$

The series resonant resistance of the inductor (including capacitor box loss), needed for efficiency and load calculations:

$$R_{\text{series}} = Z_{\text{res}} / Q^2 \text{ Ohms}$$

APPENDIX B

Measuring Coefficient of coupling

The coefficient of coupling between two windings of an inductor are often needed for accurate simulations. Measuring the mutual inductance and coefficient of coupling are easy if you own a digital LCR meter. First measure the inductance of each winding, L1 and L2, by itself. Next measure the inductance of both windings in series aiding, $L_{\text{aiding}} = (L1 + L2 + 2M)$, where M is the mutual inductance. Now reverse connections to one of the coils and measure the inductance of both windings in series bucking, $L_{\text{bucking}} = (L1 + L2 - 2M)$. M can now be calculated:

$$M = [L_{\text{aiding}} - L_{\text{bucking}}] / 4.$$

The coefficient of coupling k can now be found:

$$k = M / [(L1)(L2)]^{1/2}$$

Note that when k=1 (perfect coupling), LT-Spice always assumes that the turns ratio of two windings is $(L1/L2)^{1/2}$. If you wish to add a 10-turn secondary winding to a 300uH, 100-turn inductor, LT-Spice must be told that the secondary winding has an inductance of $(300)(10/100)^2 = 3\text{uH}$. If k is later changed to a real-world value less than 1, the no-load voltage on the secondary winding will correctly drop as though the turns ratio had increased. There will also be leakage inductance.

(Continued on page 14)

(Continued from page 13)

APPENDIX C Modeling Coupled Inductors and Tapped Coils in LT-Spice

Coupled windings

To model a coupled inductor, you must first know the inductance of one winding and the primary-secondary turns ratio. In a real physical inductor, the Q can be measured as in **Appendix A** so the series resistance of each winding can be included, accounting for the loss. The LT-Spice model requires entering the winding inductances, then internally calculates the turns ratio of a perfectly coupled coil as the square root of the inductance ratio. Using the 22 inch tapped coil loop from Example 1 (see Figure 6a), The total loop winding is $L=522\mu\text{H}$. Then the inductance of the secondary is:

$$L1=522(3/19)^2 =13\mu\text{H}$$

Go to Edit\Spice Directive and type `K1 L1 L2 1` to perfectly couple the coils together with a coupling coefficient of 1. If the method of **Appendix B** has been used to measure k of your actual inductor, then the real value should be included (or you can guess). Nothing else has to be changed.

Tapped Windings

It is not hard to model a tapped inductor with a coupling coefficient $k=1$. Refer to figure 6b. If the total loop is 19 turns with inductance $L=522\mu\text{H}$, and the tap is at 3 turns from the bottom, as before:

$$L1=522(3/19)^2 =13\mu\text{H}$$

$L2$ must be calculated from the 16/19 turns ratio:

$$L2=522(16/19)^2 =370.2\mu\text{H}$$

The difficulty occurs when the coupling coefficient k is changed to a value less than 1. The total inductance L will change. For example, if k is changed to $k=0.8$, the mutual coupling M from **Appendix B** is:

$$M=k[(L1)(L2)]^{1/2} =55.5\mu\text{H}$$

Then the total inductance will change from $522\mu\text{H}$ to:

$$L=L1+L2+2M=13+370.2+2(55.5)=494.2\mu\text{H}$$

If L is part of a resonant circuit, the tuning will be disturbed. The process of computing new values for $L1$ and $L2$ is not worth the effort, and must be repeated for each new value of coupling coefficient. If k is less than 1, it is best to simply model a tapped inductor as though it had separate coupled windings.

REFERENCES

- 1) LT-Spice is available for no cost at <http://www.linear.com/software>.
- 2) Pease, Brian (1996) *3496 Hz Beacon Transmitter and Loop*, CREGJ 23, pp. 22-24, March 1996.
- 3) Raab, F. H. (1977) *Idealized Operation of the Class E Tuned Power Amplifier*, IEEE Trans. Circuits Syst., Vol CAS-24, pp. 723-735, Dec. 1977.
- 4) Mallory, Mark (1988) *Optimizing the "Simple Beacon" Transmitter*, Western Update 59, Sept. 1988. Available on the Internet at http://www.usmc.com/~turner/mpm_class_e.html.
- 5) Pease, Brian (2004) *An Improved High Power 3496 Hz Radiolocation Beacon*, Speleonics 24, Vol. VI #4, pp. 8-9, Aug. 2004. Available on the internet at <http://www.caves.org/section/commelect>.
- 6) Pease, Brian (2004) *Greater Efficiency With a New Radio-location Beacon*, CREGJ 56, pp. 12-14, June 2004.

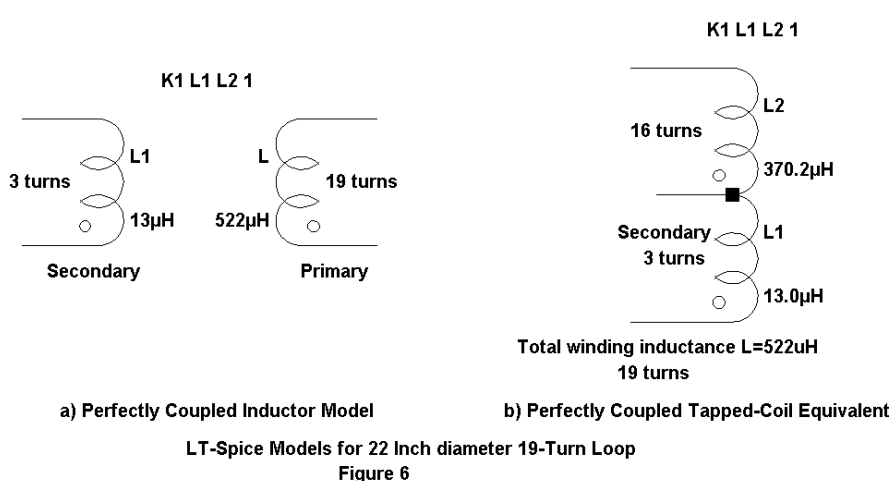

Princeton Tec Yukon HL Hybrid+ Headlamp

© 2004 John T. M. Lyles

The Yukon HL (“hybrid LED”) is Princeton Tec’s second headlamp with a Luxeon one Watt LED. Their Matrix 2 has a single Luxeon side-emitter LED with a reflector and two AA cells for power. The Yukon HL has the side-emitter LED plus reflector, with three AA cells, and a separate diffused LED mode using three 5mm white LEDs mounted around the periphery of the reflector. A simple push button is used to cycle the spot or flood mode. According to the package, the HL has a burn time of 25 hours for the 1W LED to 120 hours for the ‘low power’ LEDs. I bought two Yukon HLs on sale for \$40 each, normally retailing for \$60. This appealed to me, getting a Luxeon 1W focused beam and a floodlight in a waterproof housing for forty bucks. After all, I have been a diehard halogen bulb burner for many years, and only recently succumbed to using a “hybrid” Petzl MYO5 and Tikka.

Hacking (into) A Headlight

After reading the absurd 120 hour claim, I decided to bench test one before taking it caving. With a power supply I discovered that Princeton-Tec didn’t use active current regulation on either LED setting. Both beams appeared to be ballasted with resistors, based on the observed fall off of LED current with supply voltage. Worse yet, the three paralleled LEDs drew more current than the 1W at some voltages. Approximately 500 mA was measured with fresh batteries, leaving each LED operating seriously overdriven. Meanwhile, the 1W setting consumed 450 mA with fresh batteries, and dropped rapidly to about 70 mA with 3 volts applied. With this evidence, I was compelled to open the headlight to determine if something could be done to improve the situation. Two screws were removed from behind the reflector, but the two halves of the housing would not separate. As I applied force to the metal base around the LED, my pliers slipped and damaged the edge of the side-emitter LED lens, molded of fragile clear plastic. Now that the illumination pattern was distorted, I had to get the light apart for a replacement LED. Using an X-acto knife, I was able to cut around the circumference of the lamp, along the seam. Eventually a black epoxy separated, and the lamp was apart (fig. 1). The back half had ample empty space (fig. 2) for “improvements”.



Fig. 1



Fig. 2

Curiously, the LED is mounted in a standard PR flashlight bayonet base (fig.3, left), marked “Princeton-Tec 3AA”. The base of the LED is soldered to a hole in the circuit board, with a wire soldered to the positive dimple at the bottom. A telephone call to customer service yielded more bad news. PT does not sell replacement LEDs for this light, and could only offer to repair it if I returned it to the factory, if it was a warranty failure. This was not an option now that I had broken through the epoxy seal. I autopsied the PT LED and found a tiny circuit board in the base, with space and marking for various surface mount components. However, it was only populated with two Ohms of series resistance for current control. The Luxeon emitter was mounted on an aluminum slug heat sink, which filled most of the base.

LEDdynamics has a device called Everled, a 1W side-emitter with a flashlight PR base. It contains internal active current regulation for any flashlight from 1 to 6 volts. I bought one for \$34 from brightguy.com and proceeded to fix my Yukon HL. The Everled is epoxied into a brass PR base, and the lower edge must be polished with abrasive paper before being soldered. I also used a drop of liquid flux to get the solder to wet the brass and stick near the base to the circuit board, although it took a lot of heat from a Metcal station. Figure 3 shows the original PT LED and the Everled. They are almost the same length, but I added a thin internal tooth lockwasher (type used for potentiometer

(Continued on page 16)

(Continued from page 15)

and switch shafts) below the rim on the base, to center the focal point of the reflector for the side emitter. This silver washer can be seen in the center of the base below the flange in figure 4.



Fig. 3



Fig. 4

The Everled has a greener hue than the original PT LED, as I compared my two headlamps. It isn't objectional, just different. Otherwise the illumination is similar, and the spot beam focus is about one turn from where the reflector is screwed in tight. I probably could have left out the thin washer and gotten more of the base to fit through the circuit board to make soldering easier. The light aperture of the side-emitter must be centered at the focal point of the reflector. The Everled draws about 200 mA with 4.5 Volts applied, and the current rises to 450 mA as the battery drops to 2 volts (fig. 12). It doesn't appear to be operating at the maximum allowed power for the emitter. I ran a test to verify that it would not overheat and melt the plastic reflector. With constant current now provided inside the Everled, I went on to the second problem with the Yukon HL, the overdriven 5 mm LEDs.

Picking a Regulator

I began this work by plotting LED current versus battery (power supply) voltage. This became my standard test for all schemes tested, and is reproduced in figure 5. The original LEDs each had a 3 Ohm series resistor. First I tried a

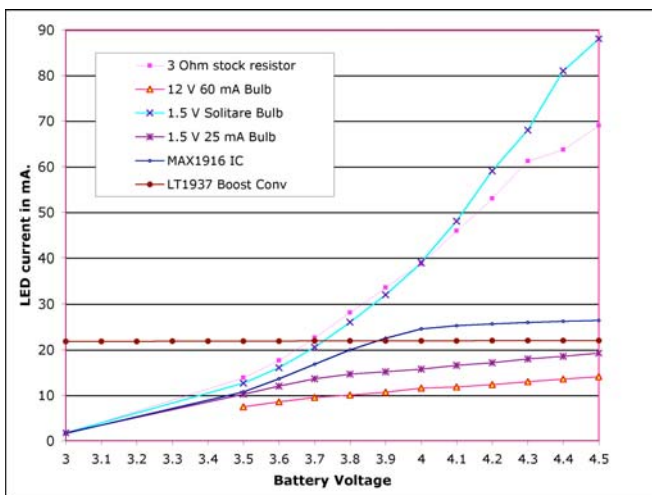

Fig. 5

technique that Brian Pease suggested in [1], using small incandescent bulbs as a nonlinear resistor (having appreciable thermal coefficient). I tried the 1.5V 25 mA grain of wheat bulb from Radio Shaft, also trying their 12V 60 mA bulb and a 1.5V 250 mA Maglight Solitaire bulb. The 12V bulb stabilized the current fairly well, but only at about 10 mA. There was no space to parallel two of these for each LED, so I looked to electronic regulation as a solution. I tested a Maxim MAX1916, which has three parallel outputs, each having linear current regulators mirrored from a common transistor for matching. It required that I have a stable reference voltage for its brightness control pin, so I used another regulator IC to accomplish this. The MAX1916 linear regulator was inadequate to supply the 3.6-3.8 volts required for white LEDs, especially when the battery dropped below 4 volts (1.33 V/cell, not especially low). This can be seen as a knee in fig. 5.

Charge pump boost converters are also available for LED current sources, such as the MAX1912. Charge pumps do not require inductors, but are very inefficient over portions of the desired range of battery voltages. The situation improves when the terminal voltage and output voltage are similar (around 3.7 volts for white LEDs). For this reason I did not consider them for a caving light. Finally I evaluated several switch mode boost converter IC's from Linear Technology and Micrel. The LT1937, the MIC2287, the Zetex ZXLD1937 and the Catalyst CAT37 all have similar

(Continued on page 17)

(Continued from page 16)

pinouts and operating parameters. There must be a de facto standard for LCD backlighting controllers having 3-5 LEDs with these chips. They all have their internal feedback point at 95 mV, which allows using a low value current sensing resistor in the ground lead of the LED string. This improves efficiency over boost voltage regulators that need 300 mV to 1.2 volts for feedback control. The new parts switch at 1.2 MHz and use tiny inductors and ceramic capacitors. The Linear Technology LT1937 hookup schematic is shown in figure 6, which drives 15 mA in three LEDs. I changed R1 to 4.3 Ohms to get ~21 mA, current being determined from Ohms law (where $I = 0.095 / R1$). The current remained stable at 21 mA per LED down to 3 volts in figure 5, but actually didn't drop out until below 2.3 volts. It was a great improvement over resistors, lamp bulbs, or linear current regulators. Later, after a week of caving, I modified R1 to 3.3 Ohms, using three 10 Ohm surface mount resistors in parallel. This yielded 27.8 mA, which drove the LEDs harder but should give better illumination for caving. In figure 5 the LT1937 V/I curve is plotted as a horizontal line, and this continues below the 3 Volt minimum shown. The power efficiency curve of figure 7 was taken with input voltage/current and output voltage/current measurements - current being constant for the LED.

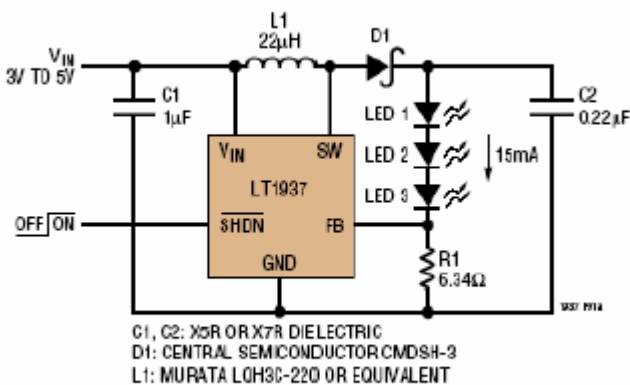

Fig. 6

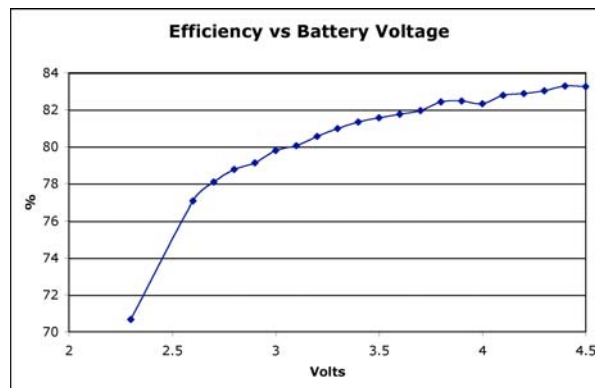

Fig. 7

Construction

Installation of the LT1937 PWM switching regulator was simple. Linear Technology designed their evaluation board (#484) with a very compact footprint for the active components. I cut apart the evaluation board using a Dremel tool, and reduced the size from 2 x 3 inches to about the size of a dime (figures 8 and 9 show this board). The solder mask was scraped from the traces and flying leads were attached. There is ample room inside the back of the headlamp housing to incorporate the trimmed LT1937 eval. board. I modified the PT circuit board for the 5mm LEDs from parallel to series connection, cutting traces, adding jumper wires, and removing the 3 Ohm resistors. The new regulator board fits on the opposite side from the power button (figure 10). With this setup, I now have separate regulators working for the three white diffused LEDs as well as the 1 W spot beam. I did not incorporate current adjustment capability in this unit, as it now had a high current spot beam for occasional use, and lower current drain for the diffused beam of the three 5mm LEDs.

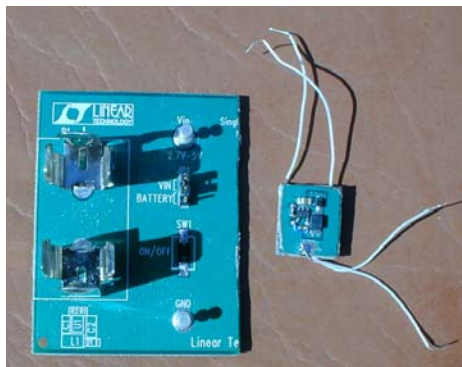

Fig. 8

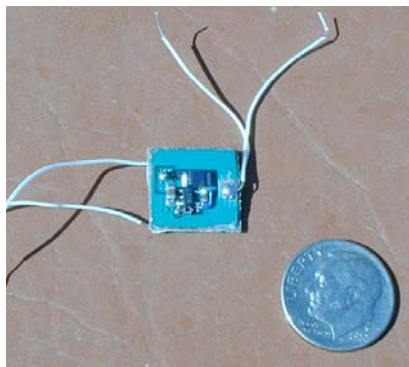

Fig. 9



Fig. 10

(Continued on page 18)

(Continued from page 17)

Operating Results

I recorded the power supply voltage and current drawn for the original Yukon HL and the modified version. The measurement was then repeated for the second LED mode for each Yukon HL. The results of these V/I curves are shown in figures 11 and 12. The slope of the curve is positive for the resistor biased LEDs, and negative for the electronic regulated LEDs - a characteristic of constant power discharging. The boost regulators easily provide output close to the LED forward voltage drop when the batteries are fresh, and as they are depleted the regulator takes more current to boost the voltage to the level required to keep the LED current constant. The low end of operation for each LED is noteworthy.

Fig. 11

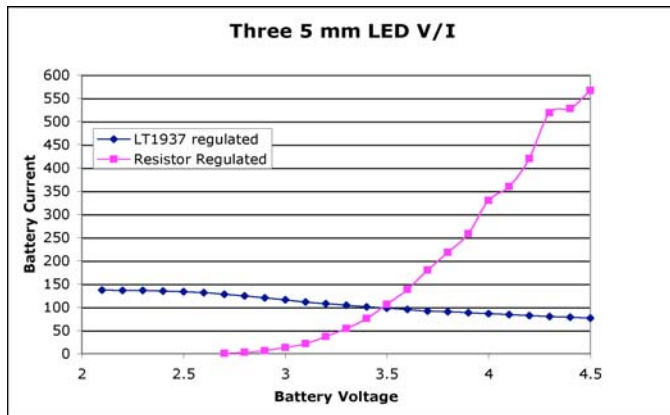
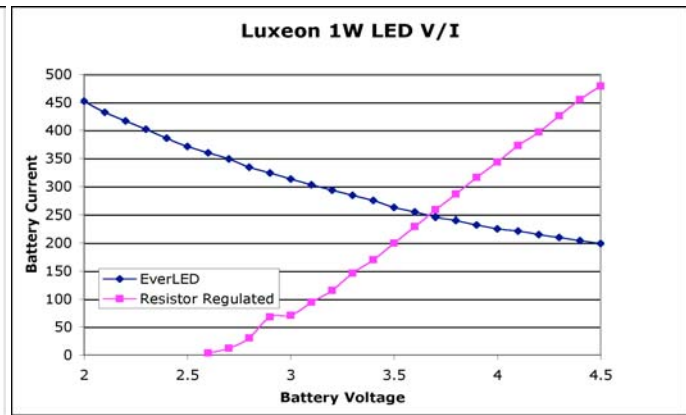

Fig. 12



The resistor-biased LEDs extinguish somewhere above 2.5 Volts, while the active regulators die at or below 2 Volts. Besides the overall leveling of the illumination over the life of the battery, there is an operational extension to lower voltage, before the light stops. This demonstrates a problem with using AA cells in series, however. While the regulator could work at a lower voltage, the batteries tend to die quickly at about 1 Volt per cell. Operation below 3 Volts is therefore not reliable. Using two cells would start with 3 volts, and then regulation would again drop out at 2 volts, leaving about a half volt per cell of actual usage before shut off. With three cells the usage is about the same per cell, about a half volt each before they quickly die. Internal resistance increases in batteries as they discharge [2]. Hence the terminal voltage is depressed further when the current draw is higher. An important advantage of higher initial voltage (more cells) is that the overall current is less with electronic regulation, so that the battery life is extended.

Comparison testing between the second Yukon HL (unmodified) and the modified light confirmed that the modified headlamp was superior for uniform brightness. It also drains the batteries more efficiently than before, where the light was overdriven with fresh cells and then dwindled to nearly useless for a long period before cell replacement. I set up a test system using a UDT 10AP pin photodiode, which I bought surplus for \$10. This filtered device approximates the human eye response. It fitted into a paper towel core tube, and the light fitted at the opposite end. By shielding it this way, I was able to measure the relative light intensity versus battery voltage over time, without interference from ambient room light. I plotted the voltages from the detector and the battery on a chart recorder. Fresh (same batch) AA cells were used for each test run. The batteries were Kirkland brand alkalines, bought at Costco.

The first plot has a compressed horizontal (time) axis and covers 2.5 days of testing. The upper trace is relative light output from the three 5mm LEDs and the lower trace is battery voltage, at 1 V/division. The time scale is 0.5 hr/div. for fig. 13.

The battery voltage plot (red) was added to the test several hours after it began, explaining why it begins at 3.8 volts. The experiment was terminated when the lamp was very dim, being useless for caving. Battery voltage was down to 3 volts (1 V/cell) after 48 hours, and the light output kept dropping. At this rate of discharge, it is possible that the Yukon HL could meet the manufacturers claim for 120 hours burn time, with virtually useless light. The current drain on the cells was so low at this point (13 mA total for all three LEDs) that the batteries could continue to supply voltage for an extended period.

(Continued on page 19)

(Continued from page 18)

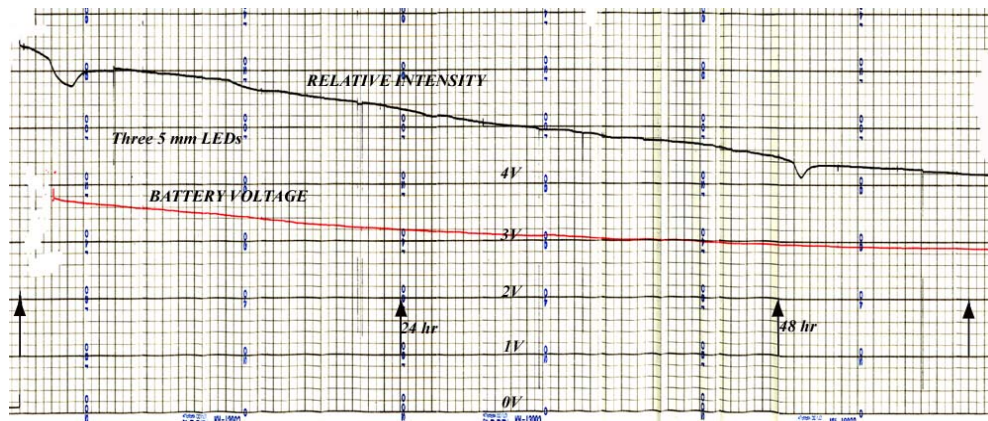

Fig. 13, Original (Stock) Yukon HL Discharge

Compare this performance with the results from the modified Yukon HL, shown in figure 14. This plot has a time scale of 1 hr/div. For this plot, both LED modes were tested and the results superimposed on the same scales. The intensity for both remained relatively constant until the battery lost at least once cell. For the 5 mm LEDs the terminal voltage dropped to 3 volts in 24 hours and the intensity plummeted shortly thereafter. One cell died first (zero volts) and the total voltage dropped to 2.1, killing the light. When the LT1937 circuit was originally set for 21 mA of LED current, this lifetime was 32 hours. The tradeoff here is brighter light versus another 8 hours. For the Luxeon LED mode, the terminal voltage reached 2.5 volts in 5 hours, when the illumination dropped. In this case it appears that two cells died leaving only one at a volt. It would be interesting to see if a different brand of alkaline cells had closer matched discharge characteristics.

5 mm LEDs the terminal voltage dropped to 3 volts in 24 hours and the intensity plummeted shortly thereafter. One cell died first (zero volts) and the total voltage dropped to 2.1, killing the light. When the LT1937 circuit was originally set for 21 mA of LED current, this lifetime was 32 hours. The tradeoff here is brighter light versus another 8 hours. For the Luxeon LED mode, the terminal voltage reached 2.5 volts in 5 hours, when the illumination dropped. In this case it appears that two cells died leaving only one at a volt. It would be interesting to see if a different brand of alkaline cells had closer matched discharge characteristics.

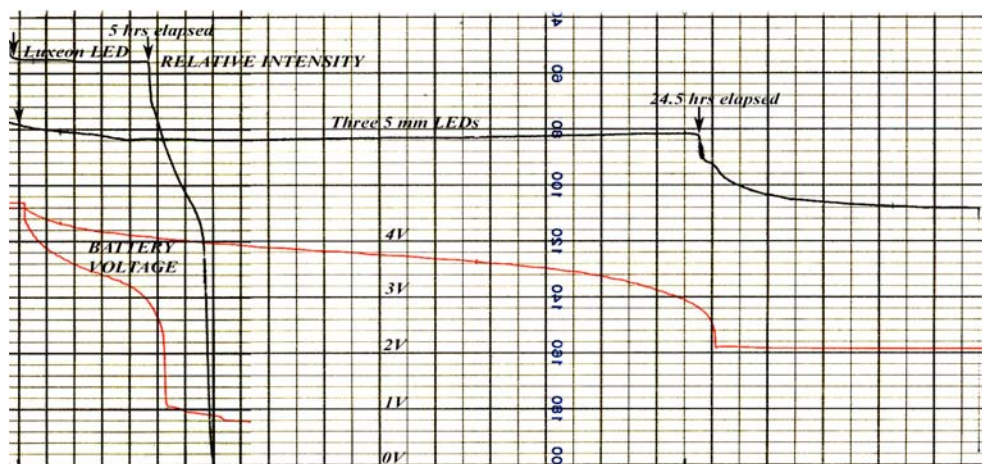

Fig. 14, Modified Yukon HL Discharge

Field Testing

The modified Yukon HL was tested during a week-long expedition in Lechuguilla Cave, New Mexico, in August, 2004. With 21 mA for the 5 mm LEDs the illumination was adequate for travel as well as surveying and climbing. I preferred the broad flat beam from the linear array of five LEDs on the Petzl MYO5 for this reason: The MYO illuminated the ground more uniformly and was better for travel in the cave. When I returned home, I opened the Yukon again, and changed the current setting resistor for the 5 mm LEDs to raise the operating current from 21 to 27.8 mA. The brightness increased a small amount, and the LEDs do not exceed their absolute maximum rating of 30 mA. According to Nichia's NSPW500BS data (assuming these are Nichia white 5mm LEDs) there should be 25% more luminosity.

Summary

My Yukon HL now has current regulation for both the 1 watt Luxeon LED and the three 5mm white LEDs around the reflector. Battery life is reasonable, somewhere less than 24 hours depending on mixed usage of the high beam Luxeon LED. The modified Yukon HL is not a "120 hour" headlamp as advertised, but it will supply constant light for a reasonable length of time before finally dropping out. Now if only Petzl would develop a MYO without the halogen bulb, but with a focusable Luxeon LED. I guess the 1W LED has convinced me to go all solid state.

[1] Pease, B., "Simple Current Limiting for LED Flashlights for Longer Battery and LED Life", Speleomics 22, September, 2001, p.14.

[2] Loo, S., and Keller, K., "Single-cell Battery Discharge Characteristics Using the TPS61070 Boost Converter", Texas Instruments Application Report SLVA194, August, 2004.

A Luxeon LED for the Petzl MYO 5

© 2004 John T. M. Lyles

After previously modifying a Princeton Tec Yukon HL headlamp[1], I field tested it in Lechuguilla Cave. This demonstrated that the three 5 mm white LEDs around the periphery of the reflector were marginal for illumination while moving about. Some individuals have caved there using a Tikka or similar AAA powered LED array, but that's carrying low power/dim light to an extreme. They have their place as a camp light, and for surveying or moving through flat and level passages. What is really needed is a broad beam for walking, climbing and traveling through break-down, and a tight spot beam for looking across large chambers, down pits, and for identifying high leads. The 1 Watt side-emitter LED on the Yukon HL was well-suited for Lechuguilla caving, as it penetrated large rooms with a focusable beam, while keeping current consumption similar to a small halogen "torch". In search for a good combination headlamp, I considered the Petzl MYO 5. The linear array of five white LEDs below the incandescent headlamp in the MYO 5 are excellent for traveling through this cave, while minimizing power consumption for week-long expeditions. It has three brightness levels toggled by repeatedly switching power on and off with a unique but somewhat fragile switch in the focusing bezel; one counterclockwise twist sets it at low, another for medium and once again for high power. Current consumption for a full 6 Volt battery was measured at 40, 80 and 214 mA respectively, and higher for the incandescent bulb.

I had used the MYO5 for about a year, coupled with Jim Sturrock's CMT-1 (Cave Man Technology model 1) miniature dimmer module. Instead of the four C cell battery pack from Petzl, I used a heavy but indestructible four D-cell Justrite battery box. I was able to get about 80 hours of mixed LED and incandescent illumination from this arrangement on a set of batteries. A full week underground required two sets of batteries, not including a spare cell or two in case of a dud. This is a lot of weight to carry. I had used this same setup with my Roosaa-Light and halogen bulb for about five years previously. Like the Roosaa, the MYO main beam used an incandescent bulb, requiring me to remember to bring spare bulbs. The other disadvantage was the dim yellow light emitted when the battery became weak. The dimmer helped to extend the battery burn time, but once the light became yellow, memories of spent carbide headlamps were back. Two years ago, I saw Brett Cook's homemade 1 Watt Luxeon LED headlamp, made from a piece of PVC pipe. It inspired me to build my own, and modify my MYO, replacing the main beam with a Lumileds Luxeon 1 watt white LED, using the CMT-1 dimmer to adjust the brightness and power consumption of that lamp. This was not going to be a simple exchange of part A for part B, but a major chop job on the Petzl system.

The task required research to develop a current regulated converter with high efficiency, operating from the same 6 Volt battery pack as the MYO 5. I chose the Luxeon Star/O LED as the acrylic collimator optic housing fitted exactly inside the inner diameter of the plastic bezel around the MYO focusing reflector. The Star/O was readily available from the Lumiled distributor, Future Electronics. I found that a flat aluminum plate of 1.5 mm (0.06") thickness and about 9.6 cm² area is perfectly adequate to transfer excess heat from the LED substrate to the environment at full power. I tested switching converter integrated circuits from Micrel, Sipex and Linear Technology, using their evaluation boards. All three have internal FET switches and the newer models have synchronous P and N channel devices, eliminating the requirement for an external shottky diode. The Micrel MIC4682 was ruled out as it operated at 200 KHz and had large capacitors and inductors. It appeared to be an older generation part, having a 1.2 Volt bandgap reference for the feedback comparison voltage. The Sipex SP6651A operated from 400 to 600 KHz, and was advertised to deliver up to 800 mA. I configured it as a current source, using a diode drop in the feedback loop to allow a reduction in resistor value for the current sampling resistor. Both this and the Linear Technology converter used 0.8 volt bandgap references for feedback. With the diode the effective feedback voltage from the current sampling resistor could be $0.8 - 0.65 = 0.15$ volts or less. This trick was learned from the SP6648LED boost converter evaluation circuit, recommended for the Luxeon devices by Lumileds. The circuit requires a resistor back to the output pin to bias the diode for hard conduction as the feedback pin is a high input impedance. The configuration can be studied on the Sipex website by pulling up the schematic for the SP6648LED at http://www.sipex.com/products/eval_boards.htm. Applying this topology to the SP6651A buck converter worked, and I was able to get relatively high efficiencies, about 88% DC in to out, but the regulation was terrible. The output current would vary up to 10% or more over the range of battery voltage required.

When I switched to the Linear Technology LTC1878 buck converter, current regulation was excellent from under 4 to 6 volts. However, as I lowered the value of current sampling resistor to below 0.2 ohms, the device would become unstable. I was unable to empirically stabilize the loop using capacitors or RC networks. No matter what I tried, the regulator would take off and quit regulating at some battery voltages. It would manifest bad behavior by driving the LED at the maximum available current from the IC, 600 mA. Reducing the current sampling resistor was paramount to obtaining the highest efficiency from the converter, but it destabilized the control loop. As the feedback voltage

(Continued on page 21)

(Continued from page 20)

was reduced to <100 mV, circuit noise also became more of a concern for stable operation.

Eventually I gave up on the diode-drop feedback scheme and implemented an active gain stage for the current-to-voltage feedback network. The highest gain that would stably operate was 14. This meant that to get 0.8 volts at the feedback input pin, 57 mV was required from the current sensing resistor. With 350 mA of LED current, this amounted to a 0.162 ohm resistor. I settled for a parallel-combination of 0805-sized chip resistors, resulting in 0.157 ohms. The power dissipation is 20 milliwatts, so that the overall loss of efficiency is about 2% as a result. I used a micropower AD627 instrumentation amplifier (IN-amp) with a 20K ohm gain resistor to get a voltage gain of 14. The '627 operates with less than 85 uA of supply current. The resulting efficiency and regulation of the final scheme was measured and is plotted in figures 1 and 2. The black curve with dots is for the final design. It has reasonable efficiency, about 88%, with excellent regulation from 3.6 to 6 Volts at the input. This translates to constant brightness for a considerable portion of the battery life, depending on whether four or two cells are used: down to 0.9 Volts per cell for four 1.5 V alkaline cells, or 1.8 Volts per cell for two 3V Lithium cells. Note the earlier curve for the LTC1878 with a 2.4 ohm current resistor. This provides 0.8 Volts directly for feedback with 333 mA in the LED. The regulation drops to 75%, and drop out occurs at 4.3 Volts, with the larger resistor in series with the LED. It is marginally better than using a resistor for ballast without a converter IC.

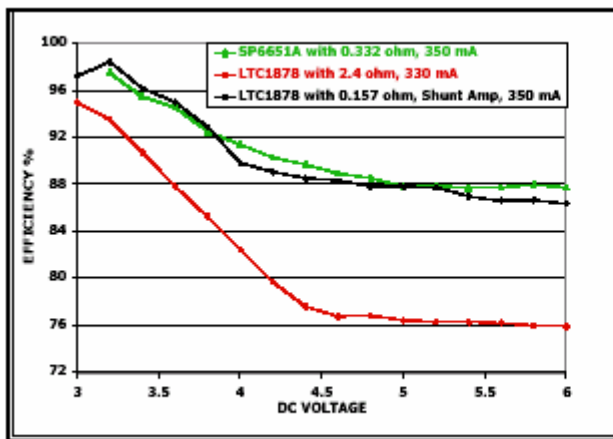

Fig. 1

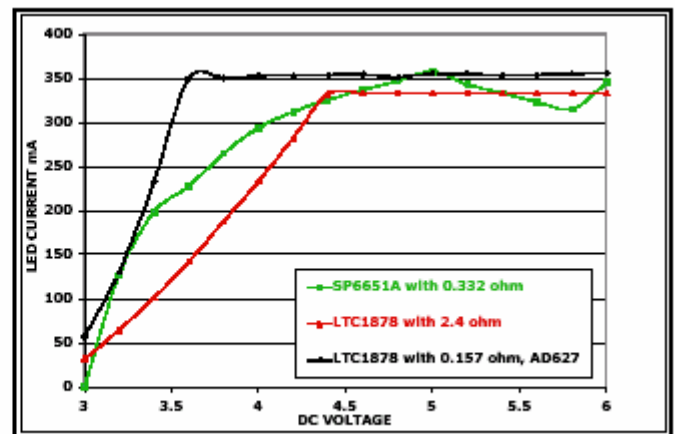

Fig. 2

Another feature of my old lamp was re-used: the CMT-1 dimmer board for pulse width modulation (PWM). The power mosfet of the CMT-1 was removed, and the gate drive from the TLC555 (or ICM7555) output connects to the RUN pin on the LTC1878. Varying the potentiometer on the CMT-1 changes the output pulse width from zero duty factor (off) to almost 100%. The LED current from the LTC1878 buck converter remains at 350 mA during the "on" time, but the time-averaged current depends on the CMT-1- provided duty factor. This allows reducing the brightness of the LED without any color shift, while reducing the DC current consumption. The CMT-1 consumption is about 30 uA. The schematic of the complete system is shown in figure 3. A switch is used to select the 1W LED or the 5 mm MYO 5 LEDs.

Construction

The LTC1878 is an 8 pin surface mount part, and it operates at around 500 KHz in the burst mode, which is the mode that offers the best performance at high continuous current. It has several pins which are unused. The PLL is left open, as it is not necessary to lock the timing. The SYNCH pin is tied to Vin. It is very important to have extremely short grounds for the input and output electrolytic capacitors, and for the ground planes to be properly designed to prevent current loops from the output to input. Extra care should be taken in keeping the feedback pin and its signal ground away from the high current loops. For this reason, I felt that using the evaluation board would be the best solution. The Linear Technology DC290A demonstration board must be modified to convert it to current regulation. R1-R7, C1 and Cfw are removed. JP3, the header and jumpers for setting various output voltages is removed. Using a Dremel tool and small cutting saw, the board was carefully trimmed to the minimum dimensions. Care needs to be taken to leave enough ground plane on both side for stable operation. Figure 4 shows the board before the central region is cut out. The turrets and all jumper pins were removed and replaced with soldered connections directly to the foil traces, once the solder mask was scraped off with an X-acto knife.

(Continued on page 22)

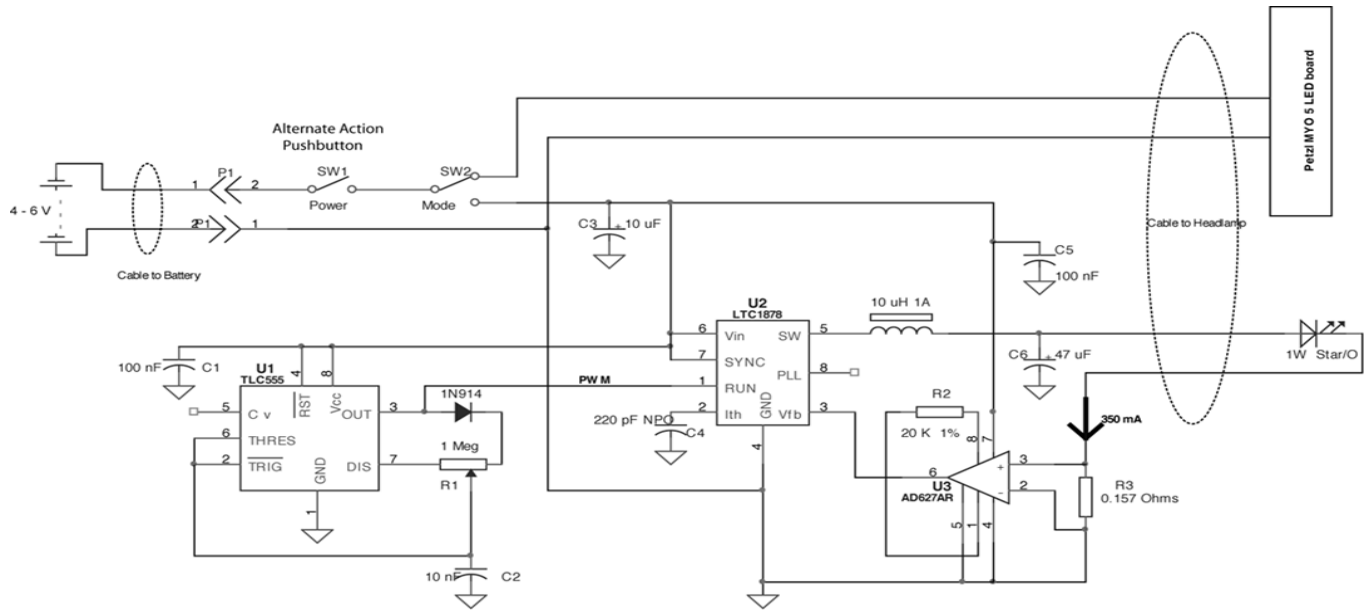

(Continued from page 21)

Fig. 3, Complete Schematic of System



Fig. 4, DC290A demo EVB

The electronics were spread among three small printed circuit boards, one being the modified DC290A demo board, one the CMT-1 dimmer module, and one for the AD627 IN-amp. A #9081 Surfboard was used for the surface mounted AD627 IN-amp. The Surfboard can be obtained from <http://www.capitaladvanced.com> or through DigiKey. The three boards were then glued to the plastic housing for the Bourns potentiometer for the CMT-1, using Marine Goop adhesive. Figures 5 and 6 show the assembly with all three boards wired in place.

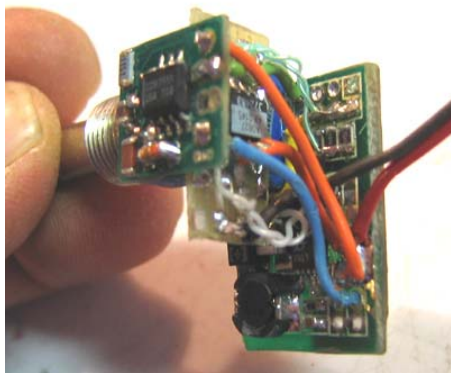

Fig. 5

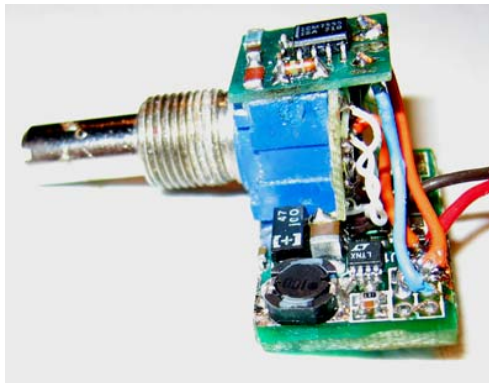

Fig. 6

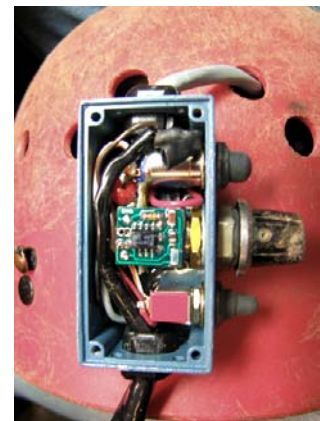

Fig. 7

With the CMT-1, the AD627 I-amp, and the trimmed DC209, this new current regulator system is densely packaged in a die-cast aluminum box (Pomona Electronics 2391), which is then mounted on the rear of my helmet (Fig. 7). Some pre-planning is required to mount the electronics module, insert a pair of Heyco plastic strain-relief bushings and cables (to battery connector and to the headlamp), and solder all of the connections. This took considerable dexterity, a stereo microscope, and a small soldering tip. With the current regulated buck circuit, any additional ohmic resistance from the wiring or contact areas for the LED adds voltage drop which then raises the minimum input voltage required for regulation.

The Luxeon Star/O (Lumileds # LXHL-NWE8) comes on a square aluminum base. This was trimmed into a round

(Continued on page 23)

(Continued from page 22)

base with a nibbling tool to fit within the Petzl headlamp housing. The power connections had been soldered at the corners of this board, so it was essential to leave a thin circuit trace close to the black housing for these. Figure 8

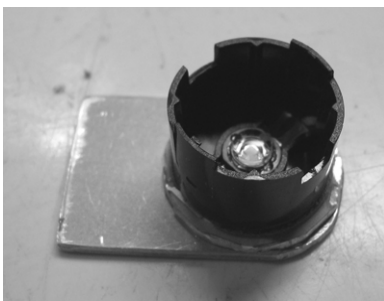

shows the modified Star/O with the collimator removed. A small piece of sheet aluminum 1.5mm thick (0.06") was cut to make a heat sink for the LED, cut in the shape shown in figure 9. One end is radiused in a semi-circle, and the other end squared-off. The Star/O is then pressed against this plate, and secured with epoxy or fasteners, and the other end of the plate extends outside of the MYO housing.

Fig. 8, Modified Star/O Base Plate

Fig. 9, Star/O on Heat Sink

To dismantle the MYO headlamp housing, I removed the lens bezel as if to replace the lamp bulb. The rubber boot was removed so that the front plastic lens, the reflector and the focusing screw could be separated. The copper strips used for the switch were removed from the focusing screw part. The front lens/focusing ring assembly will continue to be used for scratch protection of the Star/O optical surface and to keep dirt out.

Next, I pried the black lamp socket away; as it was held by small plastic posts that were staked. I used a pair of sharp needle nosed pliers to turn the two blue plastic rings, one on each side at the pivot points. They turned about 20 degrees and came loose. The MYO housing is delicate and not made for surgery such as this. The headlamp came apart from the mounting bracket. The lower half with the 5 mm LEDs was pried apart from the headlamp by using two small screwdrivers under each pivot post, to snap the halves apart. This



was difficult and I destroyed the plastic on one side with too much force. I used a Dremel tool with a cutting blade to slice a slot into the top of the MYO headlamp housing. The remaining posts for the old lamp socket were removed with the Dremel grinder to leave a flat surface behind the heat sink. The aluminum plate was inserted into the headlamp housing through the new slot as shown in figures 10 and 11. The radiused edge fitted close into the housing, leaving maximum surface area for the LED base plate.

Fig. 10

Fig. 11

Then I inserted the 4 conductor cable through the helmet (from the electronics assembly in back) into the hole at the pivot, and soldered two of the conductors to the positive and negative solder pads on the MYO 5mm LED board. The positive polarity had a red wire connected to it. It was necessary to scrape away from of the conformal coating on the LED board to reach copper traces.

I tried to mount the Star/O to the heat sink using epoxy alone, with poor success. I fed the remaining two conductors for the LED into the area in front of the new heat sink and soldered them to the thin copper traces remaining on the Star/O circuit laminate. They had just enough slack to make the connection while being able to apply epoxy to the backside. I applied Tra-Con Supertherm 816H01 thermally conductive compound, which is a two part adhesive system, to the plate to bond with the heat sink. Thermal transfer was excellent, as the aluminum plate got warm to the touch rapidly when I ran the light for a few minutes at 1 Watt. However, the epoxy bond failed shortly after testing it, possibly because the 816H01 expiration date was 1998, or because I hadn't roughened the aluminum surfaces for a strong bond. I used a file to roughen both plate surfaces and applied Devcon five minute epoxy. The heat transfer was not as good as the thermal conducting epoxy, as evident by the aluminum being only moderately warm to the touch. The slot around the aluminum plate was sealed using Silicone RTV caulk to keep dirt and dust out. This held for a weeklong expedition in Lechuguilla Cave, but broke eventually, leaving my Star/O without proper temperature management.

(Continued on page 24)

(Continued from page 23)

The final successful mounting method was to remove the acrylic collimator from the black housing and drill two #42 (2.36 mm) holes for tapping 4-40 machine screws into the base plate, with clearance holes in the base of the black housing, away from the circuit traces. I drilled oversized holes in the heat sink plate and the rear of the orange housing of the MYO5 headlamp to insert two screws. I tapped the two holes in the Star/O base plate, and polished both plates for intimate contact. A small amount of zinc oxide-based heat sink compound was smeared on one plate and pan head 4-40 machine screws were threaded through the headlamp housing and heat sink into the base plate. Excess length of the each screw was trimmed so that they did not protrude inside the Star/O, to prevent damage to the acrylic collimator when it was snapped back in. This method is highly recommended, being mechanically strong as well as providing excellent thermal transfer.

The last step was to enlarge the hole in the reflector to prevent it from touching the edge of the Star/O when the focusing ring was screwed down. While it is not necessary to adjust the focusing ring anymore, this prevents inadvertent damage to the optical surface as the bezel is screwed clockwise. A Dremel grinder enlarged the hole to 22 mm, leaving an outer reflector ring around the LED optic. This modification improved the uniformity of the projected beam spot, so it was worthwhile to continue using the reflector around the Star/O.



Fig. 12



Fig. 13, Final modified MYO 5

Figures 12 and 13 show the final product as the reflector/focusing bezel was installed. For the battery cable, I installed a pigtail and two pole keyed connector of the sealed type similar to hookups for automotive trailers. This allows me to customize the battery system, at a future date. For the initial design, I continued to use the Justrite battery box as mentioned earlier. For shorter caving trips, a small battery box with a pair of CR123 lithium cells will be clipped on the helmet. I will measure the lifetime of such as setup and report on it in another article in the future.

Summary

The MYO 5 modification turned a reasonable headlamp into a great caving headlamp. As I worked on this project I learned that Petzl was introducing the MYO XL, using a 3 watt Luxeon LED with a flip down diffuser to get a broad beam. It is believed to use a Luxeon III with a timing circuit to only allow short periods of high power operation. The modified MYO 5 works continuously, and met all of my requirements, especially for use in dry caves such as Lechuquilla Cave.

[1] Princeton Tec Yukon HL Hybrid+ Headlamp, John T. M. Lyles, 2004.
[Speleonics 25 - June 2005 {This issue - Ed.}]

80 Meter HF Radio Experiments

Paul R. Jorgenson KE7HR



Ray Keeler KE7CPI transmitting from the first test cave.

With the success of other reported HF radio use underground (most recently by Bonnie Crystal in SPELEONICS 24), some experiments were undertaken to see what was possible at 80 meters in the US ham bands using commercial off the shelf equipment. Both voice and data, using PSK31, were tried with success. Various antennas were tried with varying rates of success.

The first problem was to get caver ham radio operators willing to work on the experiment. This was solved by 'new blood' coming to the local Grotto with ham licenses and another long time caver getting his license.

The second problem is finding adequate testing for the underground station in an area with limited caves. We do have a lot of mines in Arizona, however. One abandoned kyanite (aluminum oxide) mine is inside a city mountain preserve. It is a straight tunnel that runs back over 200

feet (65 meters) into the mountain. At the back of the tunnel there is about 95 feet (29 meters) of overburden, sloping to nearly nothing at the entrance. This seemed to be an adequate testing area for the first try. The second test was in a small limestone cave that was about 300 feet (91 meters) long and ran within about 50 feet (15 meters) of the surface. The third test was in an abandoned chrysocolla mine (copper-bearing silicate) that ran horizontally into the mountain for about 600 feet (180 meters) and had about 200 feet (60 meters) of overburden at the test site. The fourth test was in a limestone tourist cave with two tour routes that were about 150 feet (45 meters) below the surface on average. These sites offered varying degrees of conductivity (hopefully to be tested later) and rock type for the tests.

The last problem is what equipment to use. For both voice and data, standard QRP ham radios were used - Icom IC-703 and Yaesu FT-817ND. For some of the PSK31 experiments a kit-built PSK-80 data radio was used (PSK-80 kit from Small Wonder Labs <http://www.smallwonderlabs.com/>). For generating PSK31 signals otherwise, laptop computers were interfaced to the HF radios running DigiPan soundcard software. The laptops used their own internal rechargeable batteries. Rechargeable sealed lead acid batteries provided the power for the transmitters.

A wide variety of antennas were tried on the surface including portable collapsible antennas, dipoles, mobile whips, and a full wave loop. Portable collapsible antennas (MFJ 1899T) were used exclusively underground. Direct connection of the small antenna to the radio was tried on the first test. It became obvious quickly that detuning effects and mechanical stability were not the best in this configuration. Subsequent tests used a portable stand made from PVC plumbing pipe and connectors. It allowed the antenna to be mounted vertically or horizontally and used a coax to the radio. This allowed physical separation and far increased the mechanical and RF efficiency. The first test also did not use the recommended counterpoise of about 50 feet (15 meters) which was used on the later tests to help keep RF feedback from being a problem.



Surface setup with the small portable antenna. The full wave loop was also used on this hill.

(Continued on page 26)

(Continued from page 25)

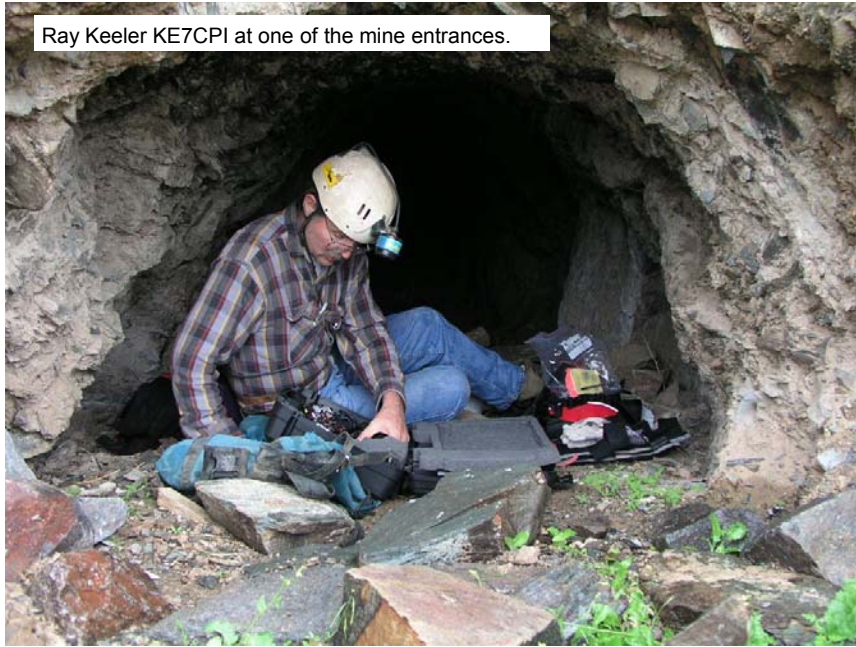

Ray Keeler KE7CPI at one of the mine entrances.

All of the tests produced excellent results. Two way SSB voice was achieved at power levels from 1 to 10 watts, often with very nice signal strengths. The small antenna performed very well and was, at the distances tested, equal to the full wave loop 3 to 6 feet (1 to 2 meters) above the ground. That was a surprising result, but the signal strength was so high during that test that what ever advantages the loop might have had were swamped by the strong signals. The most interesting result was that the dipoles, erected near the entrances in a nearly level plane with the underground station, lost the underground signal within a short distance from the entrance, while the small antenna continued to perform well.



One of the First setups in a mine.

Using the small antennas, the first test site yielded strong two way SSB signals at a horizontal distance of over 400 feet (122 meters). The underground station was 200 feet (61 meters) inside the mine. A one way SSB signal was received at slightly over 870 feet (265 meters) away on the other side of the ridge. The second test had good two way SSB communication at 300 feet (91 meters) from the entrance. Interestingly during the second test, a signal was received by the underground team from a ham that was about 40 miles (65 kilometers) distant using a horizontal dipole and 100 watts of power. That station was not able to hear (really was not listening for) the underground or surface stations which were running 10 watts. At the third test site, usable two way SSB communication was achieved at a distances of up to 500 feet (152 meters). At the fourth site, two way SSB communications from room to room in the cave were excellent at a distance of 500 feet (192 meters) which was just about as far apart as the stations could be on the cave tour route. The surface station was able to have very strong signals from anywhere in the cave using only 1 watt of power - distance up to 500 feet (192 meters) horizontally. This test was the only one done at night. The band was open and skywave QRM was running at S7 to S9. The underground stations were able to clearly copy stations from hundreds of miles away while they were 150 feet (45 meters) below the surface on average.

PSK31 signals were also copied down to the 1 watt level using the same antennas at all of the test sites. The main problem with the PSK set up was that the RFI from the laptop computer would nearly swamp the receiver in some cases, but the digital signal still prevailed. A different laptop using the same cables helped. While probably not the best digital mode for underground communications, it certainly was possible to pass text messages from one station to another with very limited power levels.

PSK31 signals were also copied down to the 1 watt level using the same antennas at all of the test sites. The main problem with the PSK



BOOMING signal from underground!

Photos by Paul Jorgenson KE7HR, Jansen Cardy ZL1AAB/W7, and Chip Haldane.